









Periphery Manual

-  S7-Panel-PLC
-  S7-Compact-PLC
-  S7-Panel-HMI
-  **Periphery**
-  Software
-  Energy Management

Index of contents

General instructions.....	4
About INSEVIS.....	5
Product family Periphery.....	6
Communication to PLC.....	6
Wiring of decentral periphery head station.....	7
The configuration software.....	7
Accessories for periphery.....	8
Status-display by LEDs in the periphery heads DP3xxC.....	9
Configuration with the Software „ConfigStage“.....	10
Basic settings.....	10
Assign the IP-address.....	11
Change target device.....	11
Addressing of the onboard periphery.....	11
Standard addressing ind the INSEVIS- PLCs.....	11
Different addressing in PLCs and addressing of decentral periphery.....	12
CPU settings.....	12
WebServer.....	14
Communication settings.....	15
RS232 and RS485.....	15
Ethernet.....	15
Profinet.....	17
CAN configuration.....	17
Decentral INSEVIS periphery.....	17
Configure decentral external periphery manually.....	18
Create library elements of your CAN-slaves.....	19
Configure decentral external peripherie by EDS-file.....	20
Decentral external periphery / motion controller pre defined.....	21
Samples for external CANopen devices.....	22
Onboard periphery of PC351V/P.....	24
Periphery module DI16 (16 digital inputs 24V).....	30
Periphery module DIO16 (16 digital in- or outputs 24V).....	32
Periphery module DO4-R (4 relay outputs 230V).....	35
Periphery module MIO84 (8 digital I/O with counter + 4 analog I/O).....	37
Process image for onboard use.....	43
Process image for decentral use.....	43
Periphery module AI4O4 (4 analog in- and 4 analog outputs).....	44
Configuration of the process image.....	46
Periphery module AI8O2 (8 analog in- and 2 analog outputs).....	47
Periphery module RTD8O2 (8 RTD-inputs and 2 analog outputs).....	50
Function module DIO8-Z (8 digital in/ -outputs / encoder inputs).....	55
Signal level.....	57
Configuration „up/down counter“.....	57
Assignment of process image „up/down counter“.....	58
Description of function pins „up/down counter“.....	59
Description of the status-LEDs configuration „up/down counter“.....	60
Configuration „Frequency and Time measurement“.....	60
Assignment of process image „Frequency and Time measurement“.....	61
Description of function pins „Frequency and Time measurement“.....	62
Status-LEDs in configuration „Frequency and Time measurement“.....	62
Configuration „Count-up counter or Time measurement“.....	63
Assignment of process image „Count-up counter or Time measurement“.....	64
Description of function pins „Count-up counter or Time measurement“.....	65
Status-LEDs in configuration „Count-up counter or measurement“.....	65
Configuration „Synchronous Serial Interface“.....	66
Assignment of process image „Synchronous Serial Interface“.....	67
Description of function pins configuration „Synchronous Serial Interface“.....	68
Status-LEDs in configuration „Synchronous Serial Interface“.....	68
Hints for downloading functions from ConfigStage into DIO8Z.....	69
Periphery module E-Mess UI (U/I for L1-3, N).....	70
General wiring of E-Mess UI.....	70
Technical data PM E-Mess UI.....	71
E-Mess topology – E-Mess- module integration.....	72
E-Mess sample topology – system net.....	73
PM E-Mess-UI process data.....	74
Process image inputs.....	74
Process image inputs.....	75
Process image outputs.....	76

Changes to older versions of the manual

- Rev. 02 / 2012: update information to analog modules AI4O4 and RTD8
- Rev. 03 / 2012: changes in measure ranges of modul RTD8, all modules with new block diagrams and wiring samples chapter „ConfigStage“ renewed
- Rev. 01 / 2013 increasment of the resolution of analog inputs by expanding the integration time
- Rev. 02 / 2013 DI16/ DIO16: in-/ output delay times changed
- Rev. 03 / 2013 description ConfigStage changed
- Rev. 01 / 2014 description ConfigStage changed
- Rev. 02 / 2014 more wirings (3-/4- wires) added, more information to DIO16 (bitwise switch off the outputs), RTD8O2 (broken wire information, AI4O4 wiring for 3-/4-wire applications corrected)
- Rev. 01 / 2015 implementation of PC351V/P onboard-periphery
- Rev. 02 / 2015 implementation of new DIO8Z...-03 and of bolt flange connectors
- Rev. 03 / 2015 rework state LEDs DP3xxC, new ConfigStage-CPU-T
- Rev. 01 / 2016 new description for download functions into DIO8-Z by ConfigStage V 1.0.14.26 with OS 2.3.5 (CPU-VI-P) / 2.3.7 (CPU-T)
- Rev. 02 / 2016 Expansion of DIO8-Z description with function download by ConfigStage and SSI-functionality PM-EMESS UI integrated, Measurement area of PT100 new described Description of decentral periphery head expands
- Rev. 01 / 2017 Expansion of DIO8-Z description with new function Info about CAN-settings and LED-Status of DP3xxX Info about max. length between CPU and extension at E-Mess-UI-scheme
- Rev. 02 / 2017 PM-E-Mess UI: Hint for grounding prohibition ref. to DIN VDE 0100-557:2014-10
- Rev. 03 / 2017 PM-MIO84 added
- Rev. 01/2019 new screenshots from 2019-Stage software inserted

Hint for better understanding by application videos

In the English YouTube-channel INSEVIS En we supply different playlists with handling videos for single details referring to functions, described in this manual.

This will help you to get familiar with INSEVIS much faster – PLEASE use it beside this manual!

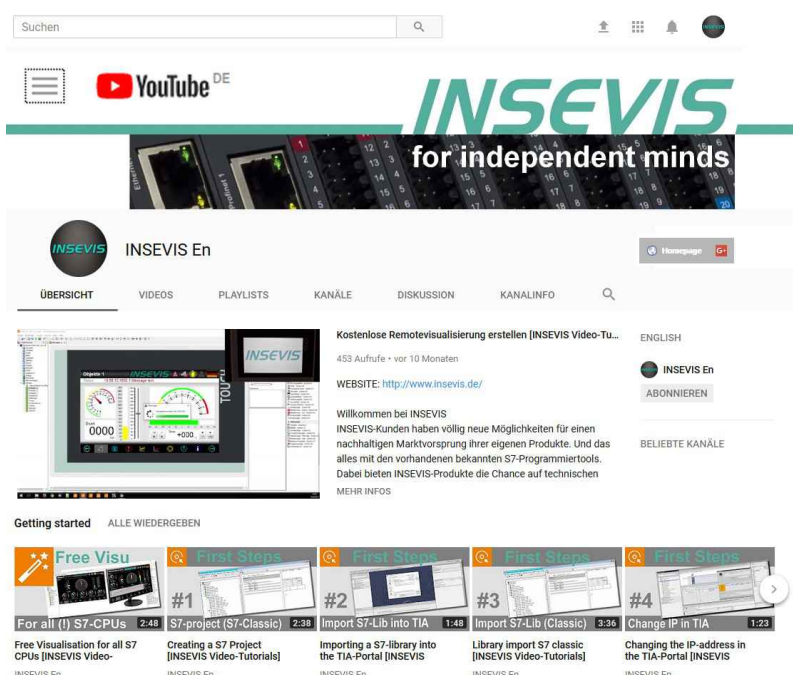

General instructions

Safety instructions

This manual contains instructions to avoid material damage and must be carefully attended for your own safety. These instructions are identified with a warning triangle with a note of exclamation inside and a signal word (*Signalwort*) below.



Danger Death, heavy bodily harm or material damage will appear, if appropriated precautions are not taken over.

Warning Death, heavy bodily harm or material damage will appear, if appropriated precautions are not taken over.

Caution Bodily harm or material damage will appear, if appropriated precautions are not taken over.

Attention means, that a unwished results or states can occur, if the appropriated instruction is not noticed.

Important means the commitment to a special behavior or operation for the safe treatment of the controller / machine.

Qualified personnel

All devices described in this manual may only be used, built up and operated together with this documentation. Installation, initiation and operation of these devices might only be done by instructed personnel with certified skills, who can prove their ability to install and initiate electrical and mechanical devices, systems and current circuits in a generally accepted and admitted standard.

Operation according to regulations

This device might be only used for this operation written in this manual and only in combination with other certified external devices. For a correct operation a proper transportation, storage, initiation and maintenance is necessary.

All valid safety instructions and regulations for the prevent of industrial accidents are to be attended carefully. The power supply must be connected to a central ground potential in a starlike wiring.



Maintenance

Modifications / repairs of an INSEVIS device might be done only by special educated and trained personnel of INSEVIS in an ESD-safe area. Every unauthorized opening might cause damages and will terminate all warranty claims.



Data security

Each customer is responsible by himself for protecting his IT-environment against illegal external attacks. INSEVIS shall not be held liable for any direct, indirect or consequential damages respect to any claims arising from the possible illegal external access to their PLCs or HMIs by Ethernet. If you are not sure, how to protect your environment ask for help at professional legal IT-companies.

Copyright

This and all other documentation and software, supplied or hosted on INSEVIS web sites to download are copyrighted. Any duplicating of these data in any way without express approval by INSEVIS GmbH is not permitted. All property and copy rights of theses documentation and software and every copy of it are reserved to INSEVIS GmbH.

Trade Marks

INSEVIS refers that all trade marks of particular companies used in own documentation as e.g.

- STEP®, SIMATIC® and other as reserved trade mark of Siemens AG.

- CANopen® and other as reserved trade mark of CAN in Automation eG

and more reserved trade marks are property of the particular owners and are subjected to common protection of trade marks.

Disclaimer

All technical details in this documentation were created by INSEVIS with highest diligence. Anyhow mistakes could not be excluded, so no responsibility is taken by INSEVIS for the complete correctness of this information. This documentation will reviewed regulary and necessary corrections will be done in next version.

Essential knowledge and experiences

To understand this documentation basic knowledge and experiences of the automation technology in general and the programming with STEP®7 are essential.

With publication of this manual all other versions are no longer valid.

About INSEVIS

S7-system components for industrial automation technology

The range of INSEVIS- product families enables an integrated solution and easy to handle for small and medium automation application with latest technology, very high quality level and with additional interfaces like CANopen® and Modbus, to be configured easily.

The easy integration of INSEVIS-products into the S7-world meanwhile is famous and exemplary. Complex communication settings will be assigned easily and intuitively, so that these properties expand the common S7-world by far. A large and multilingual visualization in a modern design is done by a few clicks and the work flow is known by every WinCCflex user. It can be simulated on the visualization PC and is accessible remote.

The S7-CPU's -V and -P are the base of the successfully INSEVIS product families with Profibus DP Master/Slave. With the new S7-CPU-T Panel-PLCs and Compact-PLCs are available with Profinet IO Controller.

Step®7-Programability

INSEVIS-S7-CPU's are programmable by STEP 7® - AWL, KOP, FUP, S7-SCL, S7-Graph from Siemens and in general command-compatible to Siemens-CPU S7-315-2PN DP. Some special INSEVIS-blocks expand the functionality and allow outstanding solutions. The S7-programming will be done by good known tools SIMATIC®-Manager or by TIA-Portal® from Siemens always.

Independence

INSEVIS-products does not base on Windows or Linux, they have an own firmware. Thereby the hard- and software can be exactly designed for a perfect co-ordination with this firmware and a low power consumption. Booting times of less than 4 seconds and completely no software licenses and a current drain of <100mA @ 24V are the result of these facts.

Get your software rid of licenses

INSEVIS stands for a clear and honest license policy, what gives the customer sustainable cost benefits. Because of the ownership of BIOS, firmware and PC-software for visualization, configuration and remote access INSEVIS can offer its products completely without licenses.

Made in Germany

Development, PCB-design and -production, test and mounting of all INSEVIS-products - all this is made in Germany. So every product is a proof for the combination of German engineering and economy and is available with a certification of German origin.



INSEVIS operates a yearly certified quality management system ref. to DIN EN ISO 9001:2015

All suppliers of INSEVIS obligate to this quality management and contribute to the high quality level of INSEVIS-products.

Already during planning these families one goal was indicated as most important: to design highest quality and ergonomics into all products.

These products were put into comprehensive validation tests before they were produced in selected and certified production lines.

INSEVIS - Made in Germany

Product family Periphery

Communication to PLC

While onboard periphery has its access to INSEVIS S7-CPU by the integrated rear bus, the head stations of the decentral periphery communicate with the CPUS by a protocol, compatible to CANopen®. Because CAN is not so common in the S7-world, INSEVIS maps its decentral periphery only by inserting the CAN-node. All others is made automatically and no INSEVIS-customer needs to know anything about CAN.

Onboard-Peripherie

digital I/Os
(24V/0,5A / 230V(5A))
analog I/Os
(U,I,R / 12-16 bit)
counter
(5V/24V/RS422, 125kHz)



1...127x Dezentrale Peripherie DP3xxC

digital I/Os
(24V/0,5A / 230V(5A))
analog I/Os
(U,I,R / 12-16 bit)
counter
(5V/24V/RS422, 125kHz)
all CANopen slave
(e.g. I/Os, drives, FCs, etc.)

Periphery modules

Decentral head stations DP303C/DP307C/DP311C

with 3 / 7 / 11 periphery slots

Periphery module DI16

(16 digital inputs 24V)

Periphery module DIO16

(16 digital in- or outputs 24V / 0,5A)

Periphery module DO4-R

(4 relay outputs 230V / 3A)

Periphery module MIO84

(8 digital- and 4 analog in- or outputs)

Periphery module AI4O4

(4 analog in- and 4 analog outputs)

Periphery module AI8O2

(8 analog in- and 2 analog outputs)

Periphery module RTD8O2

(8 analog in- and 2 analog outputs)

Function module DIO8-Z

(2 Encoder inputs A,B,Z and 2 digital in- or outputs)

Hint:

More product information to all modules are available at INSEVIS-web sites in the Product / Periphery - area and contain more information for wiring and block schemes

Data valid for all periphery and function modules:

Property	Technical data
Operating temperature range	-20°C ... +60°C
Storing temperature range	(without condensation) -30°C ... +80°C
Dimension (W x H x D)	20 x 108 x 70 mm
Weight	ca. 150 g
Wire length	
unshielded (max.)	30 m
shielded (max.)	100 m
Connection technology	Cage clamp technology for cross section up to max. 1,5mm ²

Delivery scope

- Rear foil with
 - signal overview stripe (changeable)
 - inserting stripe for identification V
- Technical data

Accessories

- Connector 20-pin (lift arms/ bolt flanges) with max. 1,5mm²,
- Inserting stripes V with customer logo

Most important properties at a glance

High packing factor

By a module width of < 20mm lots of I/Os fit in a compact PLC or decentral head station. A slim mounting depth of < 95mm and an angled connection layer towards the cable channel pre-assembled cable harness

Easy configerable head station

Assign decentral head stations by 2 node-IDs only. Once directly at the head stations turn switches and once in the cost free configuration software. That's all.

High resolution

All analog INSEVIS-I/Os resolution is minimum 12Bit. If you allow a little more integration time to the inputs of AI4O4, you can increase this resolution up to 16Bit. Of course without more costs. As always at INSEVIS.

Intelligent configuration

Selecting the functionality bitwise as digital input or output. Assign the wiring of analog inputs as 2-, 3- or 4- wire configuration. Choose between current or voltage an analog I/Os. Do it all by a mouse click in the cost free configuration software.

Product family Periphery

Wiring of decentral periphery head station

INSEVIS periphery modules unite a very compact dimensions (width less than 20mm) with a large number of in- and outputs. Good viewable status-LEDs, self-printable insertion stripes and a clear and logic identification on the rear side allow an intuitively functional attribution of signals and status - so these products also make a high quality impression from their rear side too.

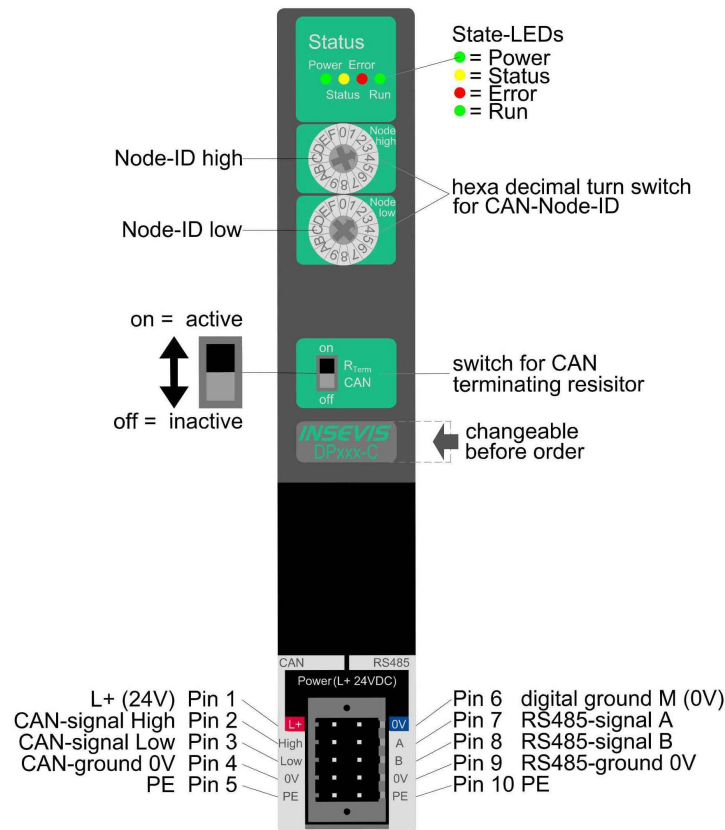

The configuration software

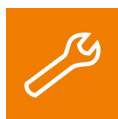

The configuration tool „ConfigStage“ is used for the easy configuration and parameterization of central and decentral periphery as well as for general CPU- and communication settings. All is done easily by drag'n drop in the „ConfigStage“, saved as a project and downloaded into the PLC by Ethernet into the system data block of the INSEVIS-S7-PLC. The programming with Siemens SIMATIC® Manager or TIA-Portal® is not affected by it.

With the „ConfigStage“ all external peripherals and intelligent drives compatible to CAN (importing EDS-file) or Modbus RTU and TCP can be included into the S7-environment in an easy way without any knowledge about these communication technologies.







It is very easy to create your own CAN-slave, to save it as macro and to use it as prefilled component again and again. Diverse S7-blocks for motion control functions of intelligent CAN-drives are available free of charge.

Product family Periphery

Accessories for periphery

There are available pin marked removable connectors either with lift arms or with bolt flanges to connect INSEVIS-devices. This allows a explicit positioning of each pin to the signals and makes the wiring easier. The wire-contact is done by maintenance free cage-clamps for max. 1,5mm² cross sections without wire end sleeves.

A grounding terminal is part of every delivery of head stations. Every periphery module contains the referring rear foil, standard inserting and signal stripes.

Figure of accessories	accessories	Article-no.	MOQ (pcs)
<p>Connectors</p>  <p>E-CON10 lift arms (pin marked connectors for max. 1,5mm² cross sections)</p>  <p>E-CONS10 bolt flanges (pin marked connectors for max. 1,5mm² cross sections)</p>	<p>For head stations Connector 2x5pin, lift arms* (discontinued in 2018, not recommended for new projects, use E-CONS10 instead) Connector 2x5pin, bolt flanges</p>	<p>E-CON10-00*</p> <p>E-CONS10-00</p>	<p>1 1..</p>
 <p>E-CON20D lift arms (pin marked connectors for max. 1,5mm² cross sections)</p>  <p>E-CONS20D bolt flanges (pin marked connectors for max. 1,5mm² cross sections)</p>	<p>For digital and mixed modules Connector 2x10pin, lift arms* (discontinued in 2018, not recommended for new projects, use E-CONS20D instead) Connector 2x10pin, bolt flanges</p>	<p>E-CON20D-00*</p> <p>E-CONS20D-00</p>	<p>1 1..</p>
 <p>E-CON20A lift arms (pin marked connectors for max. 1,5mm² cross sections)</p>  <p>E-CONS20A bolt flanges (pin marked connectors for max. 1,5mm² cross sections)</p>	<p>For analog modules Connector 2x10pin, lift arms* (discontinued in 2018, not recommended for new projects, use E-CONS20A instead) Connector 2x10pin, bolt flanges</p>	<p>E-CON20A-00*</p> <p>E-CONS20A-00</p>	<p>1 1..</p>
 <p>E-CON08 (connector for max. 1,5mm² cross sections)</p>	<p>For relay module DO4-R Connector 1x8pin</p>	<p>E-CON08</p>	<p>1</p>
<p>Customized labeling</p>	<p>Inserting stripes V with customer logo (rear)</p>	<p>E-LABV-00</p>	<p>100</p>
<p>Software</p>	<p>ConfigStage</p>	<p>-</p>	<p>free download</p>
<p>Spare parts</p> <p>Hint: grounding terminal is part of every delivery</p>	<p>Additional grounding terminals</p>	<p>E-MNT00-00</p>	<p>10</p>

Attached parts and customized designs on request.

Product family Periphery

Technical data	type of device		
Type of models	DP303C	DP307C	DP311C
Dimension W x H x D (mm)	82 x 116,5 x 92	161 x 116,5 x 92	240 x 116,5 x 92
Weight	ca. 400g	ca. 600g	ca. 800g
Mounting	to clip on a 35mm DIN-rail		
IP-leak protection class	IP41		
Operating temperature range	-20°C ... +60°C (without condensation)		
Storage temperature range	-30°C ... +80°C		
Connection technology	unlockable connector with self-lock and 2 lift-arms (cage clamp technology) for cross section up to max. 1,5mm ²		
Load voltage L+	24V DC (11 ... 30V DC)		
Current consumption	20 mA ... 275 mA	20 mA ... 350 mA	20 mA ... 485 mA
Power dissipation	0,5 W (typ.), 4,5 W (max.)	0,5 W (typ.), 7 W (max.)	0,5 W (typ.), 10 W (max.)
Start-up current	< 3A		
Onboard periphery slots for INSEVIS periphery modules	3 free slots	7 free slots	11 free slots

Status-display by LEDs in the periphery heads DP3xxC

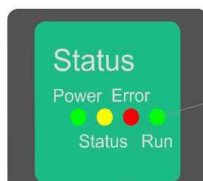

Status-LEDs

- = Power
- = Status
- = Error
- = Run

Green Power LED

signalizes proper power supply.

Yellow Status-LED

warns about missing traffic. If no data were received for > 150 ms, this LED will lit up.

Red Error-LED

signalizes communication problems, mostly caused by wiring.

1x flash: warning level reached due to too many corrupted data

2x flash: NodeGuardEvent - node returns into PREOPERATIONAL due to lost host connection

Steady light (2 seconds): internal communication error, Timeout by peripheral module

Steady light (5 seconds): switch into bus-off due to too many corrupted data

RUN-LED

Slowly blinking

signalizes node state PREOPERATIONAL: Station is waiting for configuration data. There is no process data communication.

Steady light

signalizes node state OPERATIONAL: Configuration is done, station is ready and updates process data.

Fast flashing between

RUN- and ERROR-LED

signalizes Auto-Baud-Mode after power up until first data are recognized.



Hint: Why NO automatic station return at the CAN head station?

In opposition to Profibus an automatic station return after OFF/ON of the saves is not allowed corresponding to actual specification. It means, INSEVIS-Peripherie also does not return automatically into operation after OFF/ON or PULL/PUT the CAN-cable.

Therefore the INSEVIS-CPU must be set into STOP and into RUN again, OR manual state control and new start must be done by software.
(Sample program NMT at the download web sites www.insevis.com)

Configuration with the Software „ConfigStage“

It is very easy to configure and parametrize all INSEVIS- PLCs and internal or external CAN-Periphery with the free software tool „ConfigStage“. First you select your device from the list of offered devices. After having selected your device there opens up a window with some areas.



VIDEO-tutorials available

There are available different video tutorial in the ConfigStage play list at INSEVIS Simatic®-channel INSEVIS EN. Sample programs are ready to download from INSEVIS web site.

Basic settings

- Middle PLC you selected (from rear side) without any periphery
- Left self constructing project tree with the configurable functions of the CPU, free slots and the periphery already configured
- Right catalog area with all periphery modules and decentral CAN-peripheries available
 - periphery modules will be moved by drag`n drop to the preferred slot
 - CAN-head stations will be also moved by drag`n drop to the green area in the CPUs image or to the CAN-pins in the connectors image
- Bottom Configuration area, where the properties will be configured
- Bottom right Information area of the selected module

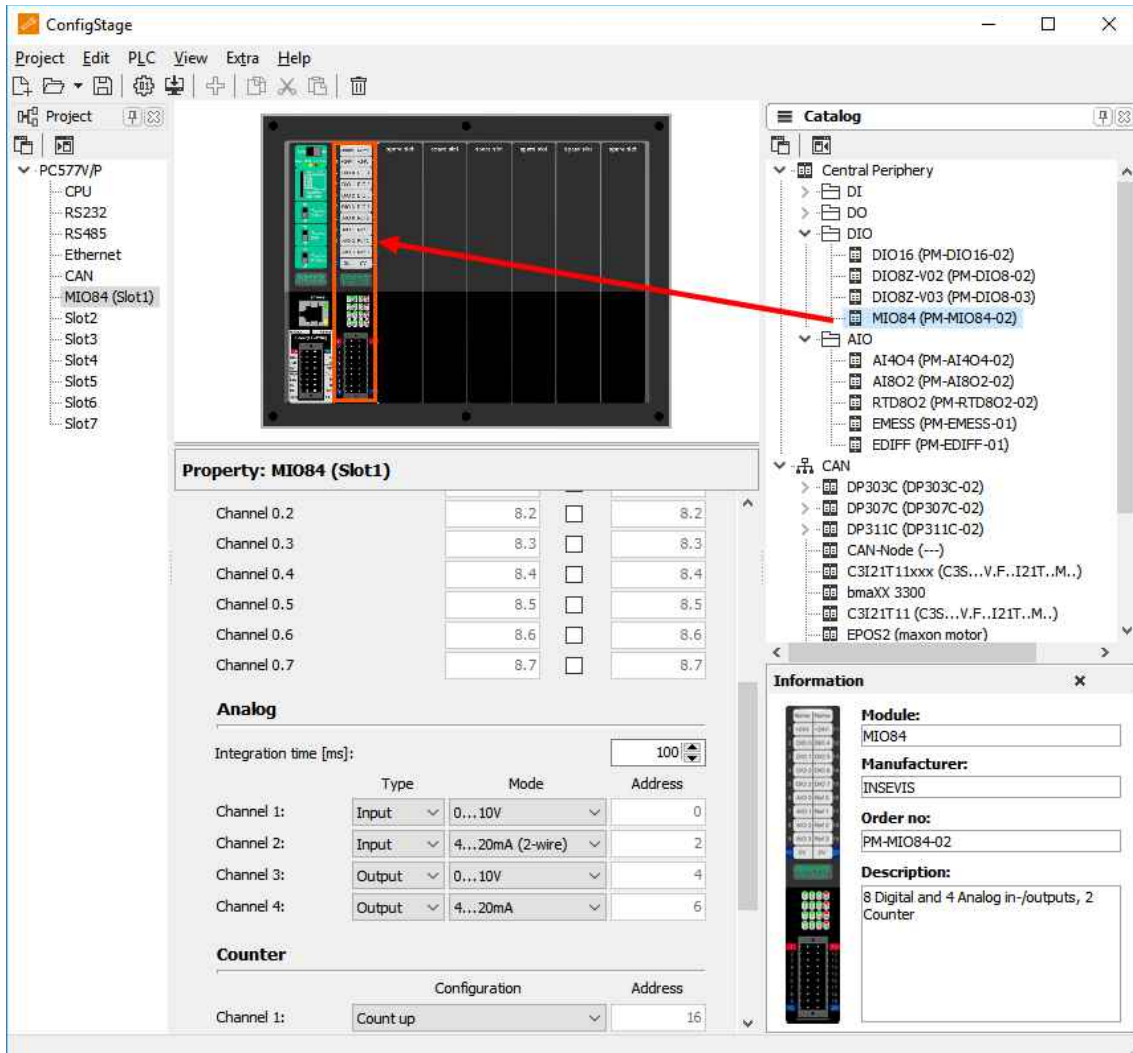

Hint: The Profibus- and CPU-configuration (without INSEVIS-specific settings for Ethernet, serial and CAN) can be made in the Simatic® Manager. The download of the Simatic® Manager overwrites all SDBs completely.

Please do config Profibus and CPU **FIRST** and download it into the PLC. Than configure all the other configurations (CPU with Ethernet, RS232/485, Modbus, CAN and (de-)central periphery and) with the ConfigStage and download it **LATER**. This download does overwrite only the configured SDBs and keeps the Profibus- and CPU-settings off the Simatic®- Manager.

Configuration with the Software „ConfigStage“

Assign the IP-address

ConfigStage can change the IP-address of the target device.

Either

- Click on „Ethernet“ in the project tree
- Enter the IP-address, netmask and router-address (if checked)

IP Protocol

IP Address:

Netmask:

Router address:

or:

- enter the download-dialog box (F12).
(There will be used the service “Accessible devices” like in other INSEVIS-Stages)

In this sample a IP-address 192.168.80.50 was assigned in the configuration, see below.

This new configuration must be downloaded to the old IP-address 192.168.80.67 once before it is active. This target-IP-address is to be

- entered manually
- or
- selected from a list of accessible devices (press „Refresh“)

For the download the PLC will be switched to STOP mode and restarts later.

ConfigStage

Target device IP address
Enter target device IP address or select the device from accessible device list.

Target device IP address:

Accessible devices

Interface:

Name	MAC address	IP Address	Netmask	Router address
INSEVIS PC57xV	00-50-C2-DF-3E-3D	192.168.80.67	255.255.255.0	192.168.80.67

Change target device

If an existing configuration should be transferred to another INSEVIS-S7-PLC, it can be done at the „Project“-menu. It helps saving time and prevents errors.

Addressing of the onboard periphery

Standard addressing ind the INSEVIS- PLCs

Without using software tool „ConfigStage“ the following address area will be set up in a standard way:

digital module: 4 byte inputs, 4 byte outputs
 analog module: 16 byte inputs, 16 byte outputs

start address \ slot	slot 1	slot 2	slot 3	slot n
digital inputs	byte 0	byte 4	byte 8	byte (n-1)x4
digitale outputs	byte 0	byte 4	byte 8	byte (n-1)x4
analog inputs	byte 128	byte 144	byte 160	byte (n-1)x16 +128
analog outputs	byte 128	byte 144	byte 160	byte (n-1)x16 +128



If a functional module FM DIO8-Z is placed, all following digital address areas will be moved for 8 byte more.

Configuration with the Software „ConfigStage“

Different addressing in PLCs and addressing of decentral periphery

If decentral periphery is used and/or other should be used other address areas in the PLCs, it will be configured with the software tool „ConfigStage“ and the set up date will be stored in the system data blocks (SDBs).

The used periphery address area can be displayed in an own window. The pull down menu „View“ → „Address overview“ creates this window with all periphery addresses used.

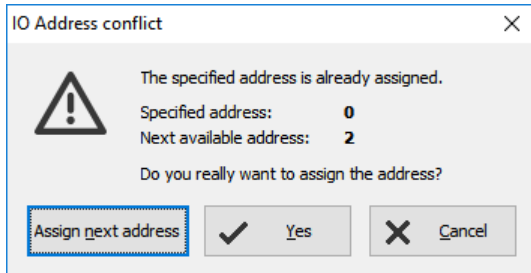

Type	Address	Module	Node	Slot
Input	0 .. 1	DI16		1
Input	1 .. 2	DI16		2
Input	8 .. 9	DIO16		3
Output	8 .. 9	DIO16		3
Input	12 .. 23	DIO8Z-V03		4
Output	12 .. 23	DIO8Z-V03		4
Output	24 .. 24	DO4R		7
Input	24 .. 25	DP303C.DIO16	1	1
Output	25 .. 26	DP303C.DIO16	1	1

When addresses will be assigned there is an plausibility check already and only if you skip the warning an address conflict is possible. This conflict is shown in the address overview in red.

CPU settings

The CPU settings are compatible to the Siemens-CPU S7-315-2PN/DP in the Simatic®-Manager. Either via project tree or by clicking directly on the image all different CPU properties can be set up easily in the ConfigStage.

General

Insert plant- and location designation

Startup

Box checked: CPU shall start, if the present configuration mismatches to actual configuration
Timeout: multiply this value with 100 milliseconds, the maximal value is limited to 1000 seconds

Diagnostic

Box checked: Reports the cause for STOP-condition to the connected devices (PG, host system,...) to be entered in diagnostic buffer too.

Know-how protection

The write or read/write protection. Password protection from Simatic®- Manager is not affected of it and to activate there.

Communication

INSEVIS-CPU's contain as well as the Siemens CPU 315-2PN/DP system internal **16 passive S7-connections**. 1

Additionally there can be parameterized **up to 16 active S7-connections** by the ConfigStage and numbered by an own ID-number.

More at **Information about TSAPs**

Configuration with the Software „ConfigStage“

Cycle

Cycle monitoring time:

(Insert it in ms, max. 6000ms = 6 seconds):

Cycle load from communication

(cycle time extension, min. 10% , max. 50%)

for communication (Ethernet, field bus, PG), visualization, file system of Micro-SD®-card)

Cycle	
Scan cycle monitoring time [ms]:	320
Scan cycle load from communication [%]:	20
Process input image area size:	128
Process output image area size:	128

The declaration of the cycle time in the PG is carried out from control point to control point. This contains communication and visualization. Independent from the S7-program an unsteady cycle time can occur.

For that case it is possible to declare a limit value in relation to the cycle monitoring time, what is used for filling out the „free time“ with time for communication (or visualization, etc).

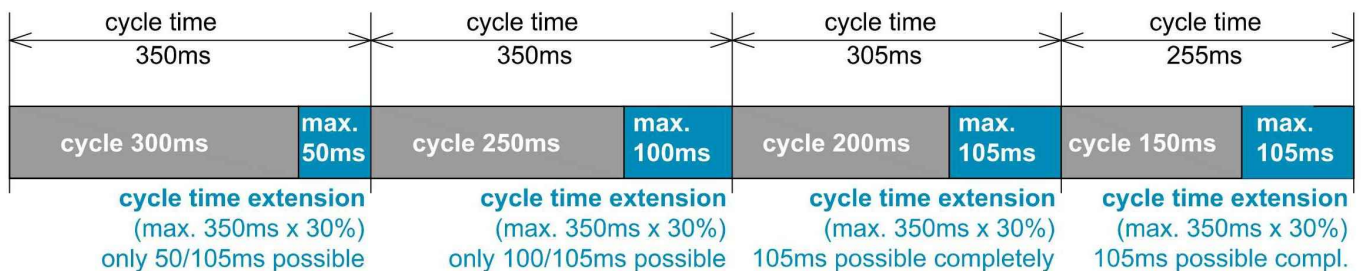

In this sample the cycle time can be extended max. by 30% of 350ms (= 105ms). If this time is not needed for communication (visualization, etc), it is available for other tasks.

Clock

check memory byte and insert its number from value 0

Retentive memory

Merkerbytes:

total 2.048 (thereof 0..15 preset)

Timer and counter:

total 256 (no preset)

Time-Of-Day interrupt

Time-Of-Day interrupt activated

Insert interval areas, starting date and starting time

Cyclic interrupt

CPUs -V/P support the OB35 only Value in milliseconds (ms), maximal value is 1 minute (60,000 ms)

CPU -T supports the OB32...OB34 too Value in milliseconds (ms), maximal value is 1 minute (60,000 ms)

Clock	
<input type="checkbox"/> Clock memory byte	0
Retentive memory	
Number of memory bytes starting MB0:	16
Number of S7 timers starting with T0:	0
Number of S7 counters starting with C0:	8
Time-Of-Day interrupt	
<input type="checkbox"/> OB10 (Priority 2)	Execution: None
	Start date: 01.01.1994
	Start time: 00:00:00
Cyclic interrupt	
OB35 (Priority 12)	Execution [ms]: 100

Configuration with the Software „ConfigStage“

WebServer

The PLCs with CPU-T inside contain a static web server, what provides

- general data (serial no., etc.),
- actual entries of diagnostic buffer,
- addresses of I/Os and,
- an fiel to require the actual value of a variable.

The activation of this web server is on the bottom at the CPU-settings.

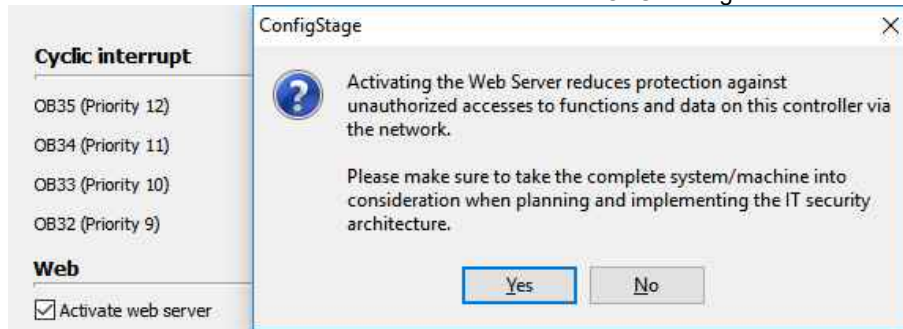

By connecting to the internet it is possible that unauthorized get access to the PLC and they could manipulate it and cause harms. The programmer and final user are responsible for installing and running suitable security actions to provide this unauthorized access. INSEVIS is not responsible and does not take over responsibility for damages caused by unauthorized access.

Configuration with the Software „ConfigStage“

Communication settings

RS232 and RS485

The assign of RS232 and RS485 is self-explanatory. If you select at the RS485 the protocol „Modbus-RTU“, you will be asked to assign the node-ID as well as to map your S7-operands to input-bits and -words and to output-bits and -words. If „Modbus Server is deactivated, Modbus RTU-telegrams will be received and sended by SFB60/61

Ethernet

If you want to use the Ethernet-interface, there are to assign up to 16 connections, to select the communication protocol and to parameterize it. Each Ethernet-connection gets a connection-ID to be assigned in the S7-program

Property: Ethernet

IP Protocol

IP Address:

Netmask:

Router address:

Connections

ID	Type	Active	Local	Partner	Partner IP
1	S7 connection	Yes	10.02	10.02	0.0.0.0

CPU-V/P: There is ONE Ethernet-interface available (RJ45)

CPU-T: There are TWO Ethernet-interfaces available (RJ45), what can be used either
 - as switch with common IP-address (left image) or
 - as seperated Ports with differen IP- (and MAC-) addresses and net masks. (right image).

Property: Ethernet

General

Operation mode
 2-port ethernet Switch
 2 separate ethernet ports

Ethernet 1
 Activate this port for use
 Transmission medium / duplex:
 Disable auto negotiation

Ethernet 2
 Activate this port for use
 Transmission medium / duplex:
 Disable auto negotiation

IP Protocol

IP Address:

Netmask:

Router:

Protection

Permit access with S7 Communication from remote partner
 Ethernet 1 (PG, PLC, HMI, OPC, ...) via
 Ethernet 2

Connections

ID	Type	Active	Local	Partner	Partner IP
1	S7 connection	Yes	10.02	10.02	0.0.0.0

Both ports can be used

Property: Ethernet

General

Operation mode
 2-port ethernet Switch
 2 separate ethernet ports

Ethernet 1
 Activate this port for use
 Transmission medium / duplex:
 Disable auto negotiation

Ethernet 2
 Activate this port for use
 Transmission medium / duplex:
 Disable auto negotiation

IP Protocol

	Ethernet 1	Ethernet 2
IP Address:	<input type="text" value="192.168.80.50"/>	<input type="text" value="192.168.70.50"/>
Netmask:	<input type="text" value="255.255.255.0"/>	<input type="text" value="255.255.255.0"/>
Router:	<input type="text"/>	<input type="text"/>

Protection

Permit access with S7 Communication from remote partner
 Ethernet 1 (PG, PLC, HMI, OPC, ...) via
 Ethernet 2

Connections

ID	Type	Active	Local	Partner	Partner IP
1	S7 connection	Yes	10.02	10.02	0.0.0.0

Port 2 can not more communicate by S7 (protection)

Configuration with the Software „ConfigStage“



Hint:

To prevent unauthorized access by the „classic“ S7-communication, the ConfigStage allows to switch off this communication at one port. This prevents an unauthorized manipulation of PLC-data.

Every connection gets a connection-ID to assign it to the S7-program. Referring to the connection type the selected connection will be parameterized in separate boxes with these parameters:

parameters at S7-connection (Active)

- Local TSAP*
- Partner-TSAP*,
- Partner-IP-address

parameters at INSEVIS-Panel-HMI

- Local TSAP*

parameters at TCP Send/Receive

- Local port,
- Partner-port,
- Partner-IP-address

parameters at UDP Send/Receive

- Local port

parameters at Modbus-TCP (Server)

Assign of S7-operand areas for Modbus-

- Input bits
- Input words
- Output bits
- Output words

(As sample the „mapping“ at Modbus-TCP-Server)

Modbus-TCP-Client will be programmed by S7, a sample is available at the INSEVIS web sites)

Property: Ethernet

IP Protocol

IP Address:

Netmask:

Router address:

Connections

ID	Type	Active	Local	Partner	Partner IP
1	S7 connection	Yes	10.02	10.02	192.168.80.10
2	INSEVIS Panel-HMI		FF.02		
3	TCP Send/Receive	No	2000	0	0.0.0.0
4	UDP Send/Receive		2000		
5	ModBus TCP Server		502		

Properties - ModBus TCP Server connection

Discrete Inputs (Bits)

Area:

Block number:

Byte offset:

Length in bytes:

Coils (Output bits)

Area:

Block number:

Byte offset:

Length in bytes:

Input Registers

Area:

Block number:

Byte offset:

Length in bytes:

Holding (Output) Registers

Area:

Block number:

Byte offset:

Length in bytes:

Configuration with the Software „ConfigStage“

Communication / Information about TSAPs

INSEVIS-CPU's contain as well as the Siemens CPU 315-2PN/DP system internal **16 passive S7-connections**. Their local TSAPs are defined by Siemens-definition xx.yy as follows:

- for PG= 01.02,
- for OP= 02.02,
- for WinCC etc.= 03.01
- xx=01 (for PG),
- xx=02 (for OP) and
- xx=03 (for WINCC etc.)
- yy for all 02 (= Slot2 for CPU)

CPU-T: Assigning properties to one or both of the single Ethernet interfaces (see image right)

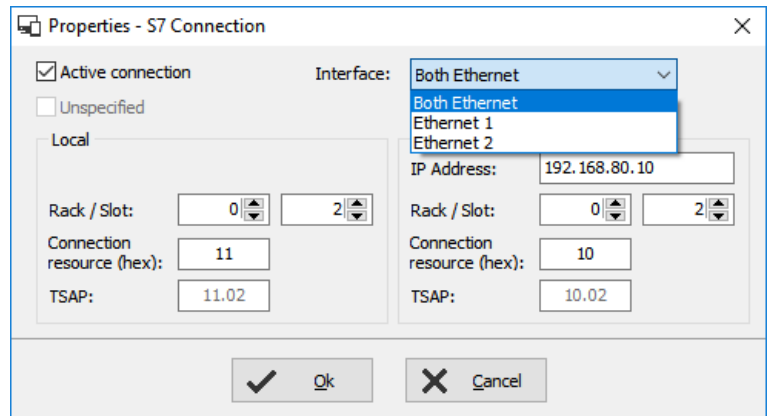

Additionally there can be parameterized **up to 16 active or passive S7-connections** by the ConfigStage and numbered by an own ID-number. Here the Siemens-definition is not valid but it is **necessary**

1. to keep the TSAPs unique and
2. to not even use the TSAPs from the system internal passive connections.

Profinet

Profinet settings will be assigned by Simatic®-Manager or TIA®-Portal (like as Profibus settings)

CAN configuration

Decentral INSEVIS periphery

There is **no need to have CAN-knowledge** to include decentral INSEVIS- periphery to the INSEVIS-S7-CPU's.

After having placed your INSEVIS head station on the CPU, this module appears in the project tree and in the display.

Now you can insert general start addresses for the head station for in-/outputs (no more possible at the single modules).

The periphery modules will be added per drag'n drop from a special sub area of the catalog tree below the CAN-title.

You type in the node-ID-number you have set up before at the INSEVIS- head stations hardware with the hexadecimal turn-switches.

Also you insert the guarding time you want. Than all i/os will be used in Step®7 like onboard I/Os of an INSEVIS-PLC.

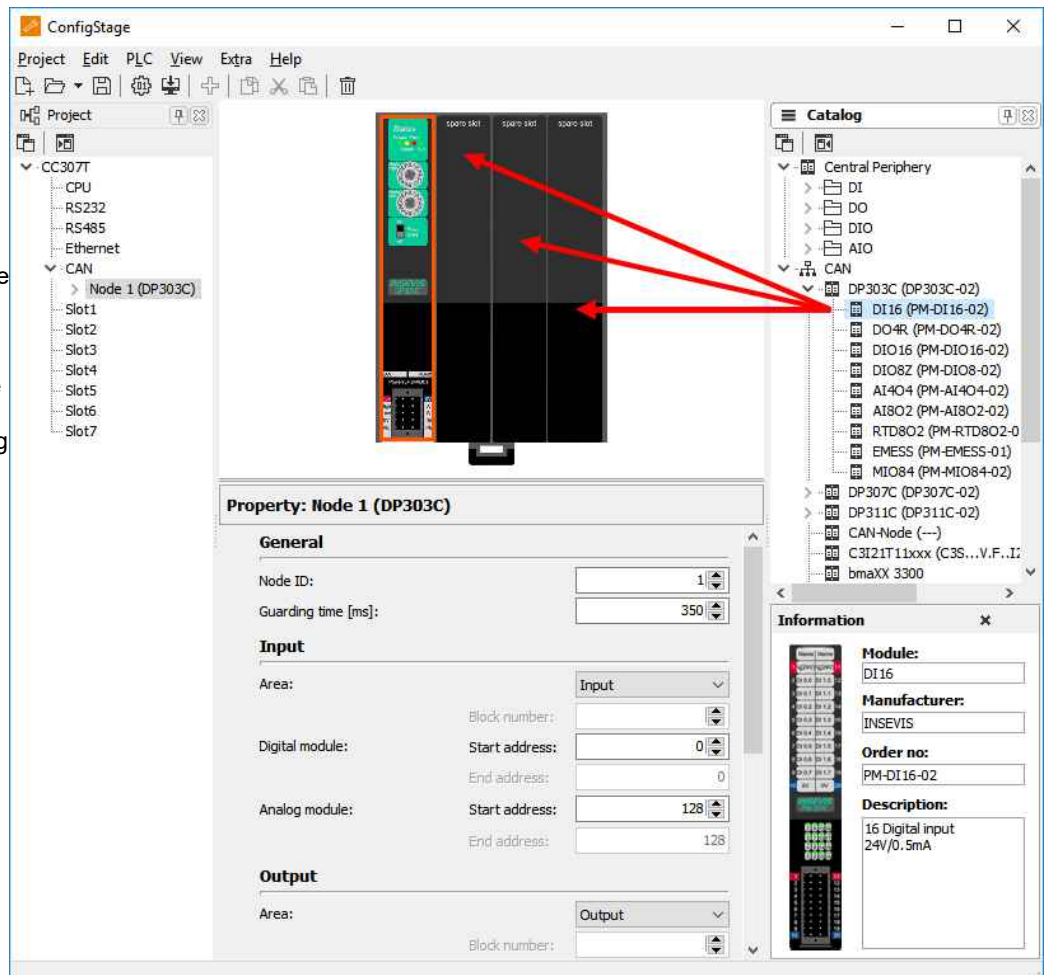

Configuration with the Software „ConfigStage“

Configure decentral external periphery manually

Instead of an INSEVIS- head station you drag'n drop a neutral CAN-node onto your CPU. Then all common settings of for the **node-ID** and the **guarding parameters** will be done.

If the field **"NMT Control"** is activated, the node will be started and stopped together with the PLC. Therefore the NMT-messages "goto OPERATIONAL" with change to RUN (after OB100, before first OB1) and "goto PREOPERATIONAL" with change to STOP will be sent to the node.

Is the node not ready while PLC starts, the "goto OPERATIONAL"-message will be ignored. The must be considered in the user program with a state request. Eventually the NMT-commands need to be programmed in the S7-program.

With the check box **„NMT-Download“** will be assigned, if the communication parameters „Guarding-Time“ / „Lifetime“ / Heartbeat-Time“ should be downloaded to the node during the start up or not. This is useful only, if these parameters are not implemented in the node itself or assigned by other tools

For the process data are available each **32 Tx- and Rx-PDOs**. If more as **4 PDOs** of it will be used, PDO-identifiers of other node-IDs will be used for it. These node-IDs should not be assigned again. (Only CiA-conform TxPDO-identifier are valid.) Received Tx-PDOs will be buffered and transferred synchronous to the control point to the process image, RxPDOs will be send event- and time-controlled in the control point always.

An 8-byte-data field on a selectable S7-operand is to assign to every PDO.

The Tx-PDO communication parameters define the sending behavior of the node, the Rx-PDO define the sending behavior of the master.

The screenshot displays the 'ConfigStage' software interface for configuring a CAN node. The main window, titled 'Property: Node 1 (CAN-Node)', is divided into several sections. The 'General' section includes 'Node ID' (set to 1), 'Device monitoring' (Heartbeat selected), and 'NMT control' (checked). The 'Device information' section shows 'Name: CAN-Node' and 'Description: General CAN-Node'. A red arrow points from the 'TxPDOs' button in the 'General' section to the 'TxPDOs' tab in the 'TxPDO Configuration' dialog. Another red arrow points from the 'SDOs' button in the 'Device information' section to the 'SDOs' tab in the 'SDO Configuration' dialog. The 'TxPDO Configuration' dialog shows settings for PDO Number 1, COB ID (According), and communication parameters like Inhibit time (100 ms) and Event time (500 ms). The 'SDO Configuration' dialog shows fields for Description, Index (hex), Sub index (hex), and Data type.

Configuration with the Software „ConfigStage“

The inhibit-time prevents a too excessive sending, when data are changing permanently; the event-time forces the sending, even if there is no data change.

Entering of single CAN-objects (Index, Subindex) in the mapping field is optional, as long the download of the mapping is not activated. Always assign the data type to define the telegrams length and to allow a real byte swapping.

With activated download of complete mapping-parameter the PLC configures the content of the PDS during start up.

To assign more configurations in the start up, **SDOs** can be defined (e.g. for operational modi or metering ranges, etc.).

Create library elements of your CAN-slaves

Optional: If this „mapping“ is made, the new configured CAN-node (CAN-slave) can be stored locally in the ConfigStage to use this part as a library element with pre-defined values.

Therefore click with the right mouse key on the just configured CAN-node.

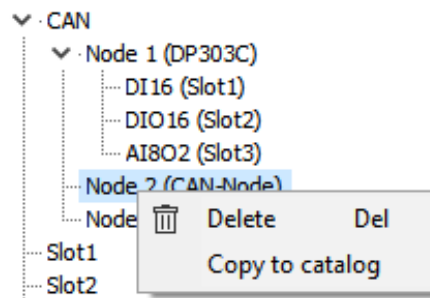

Then a new mask opens. Insert all information (and image) and acknowledge with „OK“.

So you will get an own CAN-slave, pre-defined for further use and with your internal information.



The nomenclature **TX** (Transmit) and **RX** (Receive) are at CANopen[®]-PDOs always from the CAN-nodes view (slave). It means, with a TX-PDO a node sends its input data to the PLC and with a RX-PDO it receives its output data.

Configuration with the Software „ConfigStage“

Configure decentral external peripherie by EDS-file

You need a EDS-file of the external CAN-slave you want to configure. Import it like shown here:

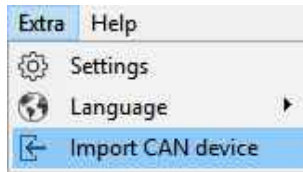

Then a new window opens like described above (Create library elements of your CAN-slave). After having assigned texts, order information and images there is an „empty“ library element, what must be configured like described in following items.

PDO configuration

By „Show CAN objects“ an object browser opens up with all CAN-objects available. These were filtered from the EDS-file automatically. Move single or multiple CAN-objects by Drag'n Drop into your configuration.

Tx PDO Configuration

PDO Number: 1 Description: []

COB ID
 Constant
 "Node ID" + Offset (hex) ID (hex): 181
 According to CIA DS301

PDO Disable-Flag RTR-not-allowed-flag

Communication parameter
 Download
 Inhibit time [1/10 ms]: 100
 Event time [ms]: 500
 Transmission type: 255

S7 Mapping
 Area: Input
 Block number: []
 Byte offset: 0

Mapping
 Download
 Data length (bytes): 8 **Show CAN objects**

	Data type	Description
1:	Byte	ReadState8_InputLines.Digital Input By
2:	Byte	ReadState8_InputLines.Digital Input By
3:	Byte	ReadState8_InputLines.Digital Input By
4:	Byte	ReadState8_InputLines.Digital Input By
5:	Byte	ReadState8_InputLines.Digital Input By
6:	Byte	ReadState8_InputLines.Digital Input By
7:	Byte	ReadState8_InputLines.Digital Input By
8:	Byte	ReadState8_InputLines.Digital Input By

CAN Objects

Search CAN object [] Show values in Hexadecimal format

Description	Index	Sub index	Data type
ReadState8_InputLines.Digital Input Byte 1	6000	01	UINT8
ReadState8_InputLines.Digital Input Byte 2	6000	02	UINT8
ReadState8_InputLines.Digital Input Byte 3	6000	03	UINT8
ReadState8_InputLines.Digital Input Byte 4	6000	04	UINT8
ReadState8_InputLines.Digital Input Byte 5	6000	05	UINT8
ReadState8_InputLines.Digital Input Byte 6	6000	06	UINT8
ReadState8_InputLines.Digital Input Byte 7	6000	07	UINT8
ReadState8_InputLines.Digital Input Byte 8	6000	08	UINT8
ReadState8_InputLines.Digital Input Byte 9	6000	09	UINT8
ReadState8_InputLines.Digital Input Byte 10	6000	0A	UINT8
ReadState8_InputLines.Digital Input Byte 11	6000	0B	UINT8
ReadState8_InputLines.Digital Input Byte 12	6000	0C	UINT8
ReadState8_InputLines.Digital Input Byte 13	6000	0D	UINT8
ReadState8_InputLines.Digital Input Byte 14	6000	0E	UINT8
ReadState8_InputLines.Digital Input Byte 15	6000	0F	UINT8
ReadState8_InputLines.Digital Input Byte 16	6000	10	UINT8
ReadState8_InputLines.Digital Input Byte 17	6000	11	UINT8
ReadState8_InputLines.Digital Input Byte 18	6000	12	UINT8
ReadState8_InputLines.Digital Input Byte 19	6000	13	UINT8
ReadState8_InputLines.Digital Input Byte 20	6000	14	UINT8
ReadState8_InputLines.Digital Input Byte 21	6000	15	UINT8
ReadState8_InputLines.Digital Input Byte 22	6000	16	UINT8
ReadState8_InputLines.Digital Input Byte 23	6000	17	UINT8
ReadState8_InputLines.Digital Input Byte 24	6000	18	UINT8
ReadState8_InputLines.Digital Input Byte 25	6000	19	UINT8
ReadState8_InputLines.Digital Input Byte 26	6000	1A	UINT8
ReadState8_InputLines.Digital Input Byte 27	6000	1B	UINT8
ReadState8_InputLines.Digital Input Byte 28	6000	1C	UINT8
ReadState8_InputLines.Digital Input Byte 29	6000	1D	UINT8
ReadState8_InputLines.Digital Input Byte 30	6000	1E	UINT8
ReadState8_InputLines.Digital Input Byte 31	6000	1F	UINT8
ReadState8_InputLines.Digital Input Byte 32	6000	20	UINT8
ReadState8_InputLines.Digital Input Byte 33	6000	21	UINT8
ReadState8_InputLines.Digital Input Byte 34	6000	22	UINT8
ReadState8_InputLines.Digital Input Byte 35	6000	23	UINT8

Configuration with the Software „ConfigStage“

SDO- configuration

By „Show CAN objects“ an object browser opens up with all CAN-objects available. These were filtered from the EDS-file automatically.

Move single or multiple CAN-objects by Drag'n Drop into your configuration. In the „Data“ field assign your parameter value.

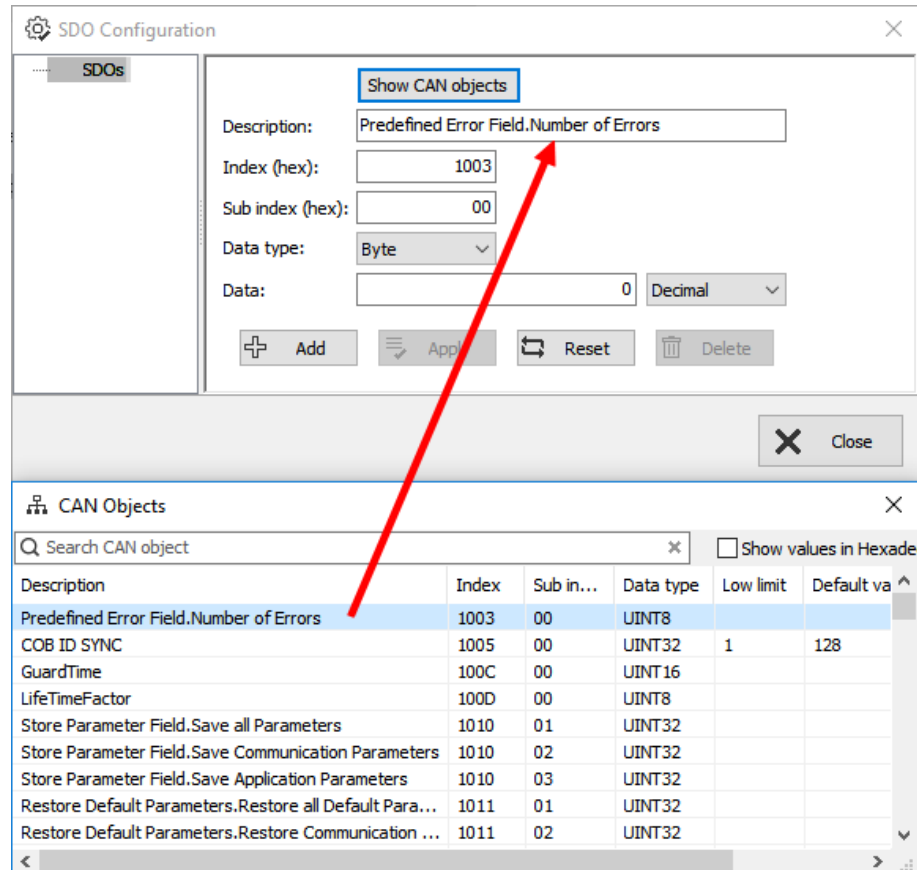

Decentral external periphery / motion controller pre defined

Pre-defined CAN-devices, especially motion controller, allow the S7-user an immediately access to these devices. Because this configuration data is open to change, it could be adapted to customers needs or extended easily.

INSEVIS offers on its website free of charge various DataBlocks to drive complex motion controllers as e.g. Parker C3, Maxon EPOS2. With these DBs it is possible to control different complex systems with one S7-program

The special advantage is the architecture with different small DBs für each function (jog, acc, dec, home,...). This allows to swap these motion engines with only a few efforts to adapt the S7-program. Normally you can re-write your program, when you replace one drive-specific large DB of one motion vendor to another large DB of another motion vendor.

The complete description with demonstration program and data blocks is available at our website

Configuration with the Software „ConfigStage“

Samples for external CANopen devices

Sample for decentral CANopen periphery ref. to DS401

If a device with digital and analog In- and outputs is used referring to CANopen-Profile DS401, the in/outs are

- digital inputs in TxPDO1, e.g. 32 bit

Datenart	Datenlänge (Bytes)	Zeige CAN-Objekte	Beschreibung
1: Byte	4	<input checked="" type="checkbox"/>	Digital Input Byte 0
2: Byte		<input type="checkbox"/>	Digital Input Byte 1
3: Byte		<input type="checkbox"/>	Digital Input Byte 2
4: Byte		<input type="checkbox"/>	Digital Input Byte 3
5: Byte		<input type="checkbox"/>	
6: Byte		<input type="checkbox"/>	
7: Byte		<input type="checkbox"/>	
8: Byte		<input type="checkbox"/>	

- digital outputs in RxPDO1, e.g. 16 bit

Datenart	Datenlänge (Bytes)	Zeige CAN-Objekte	Beschreibung
1: Byte	2	<input checked="" type="checkbox"/>	Digital Output Byte 0
2: Byte		<input type="checkbox"/>	Digital Output Byte 1
3: Byte		<input type="checkbox"/>	
4: Byte		<input type="checkbox"/>	
5: Byte		<input type="checkbox"/>	
6: Byte		<input type="checkbox"/>	
7: Byte		<input type="checkbox"/>	
8: Byte		<input type="checkbox"/>	

- analog inputs in TxPDO2 to 4

Datenart	Datenlänge (Bytes)	Zeige CAN-Objekte	Beschreibung
1: Word	4	<input checked="" type="checkbox"/>	Analog Input Word 0
2: Word		<input type="checkbox"/>	Analog Input Word 1
3: Word		<input type="checkbox"/>	
4: Word		<input type="checkbox"/>	
5: Word		<input type="checkbox"/>	
6: Word		<input type="checkbox"/>	
7: Word		<input type="checkbox"/>	
8: Word		<input type="checkbox"/>	

- analog outputs in RxPDO2 to 4

Datenart	Datenlänge (Bytes)	Zeige CAN-Objekte	Beschreibung
1: Word	8	<input checked="" type="checkbox"/>	Analog Output Word 0
2: Word		<input type="checkbox"/>	Analog Output Word 1
3: Word		<input type="checkbox"/>	Analog Output Word 2
4: Word		<input type="checkbox"/>	Analog Output Word 3
5: Word		<input type="checkbox"/>	
6: Word		<input type="checkbox"/>	
7: Word		<input type="checkbox"/>	
8: Word		<input type="checkbox"/>	

(Images in German language but self explaining)

Therewith the in- and outputs can be used on the configured S7-address (in this sample from EB0, AB0) as usually.



The PDO-number 1 is reserved for digital I/Os only.
The analog I/Os can be mapped starting from PDO-number 2

Configuration with the Software „ConfigStage“

To transfer parameters (e.g. metering ranges for analog modules), SDOs need to be configured specific referring to the vendor.

The SDO Configuration dialog box shows the following fields:

- SDOs: (empty list)
- Show CAN objects: (button)
- Description: Module Parameter data Slot 1.Parameter Byte 1
- Index (hex): 3001
- Sub index (hex): 01
- Data type: Byte
- Data: 255 (Decimal)
- Buttons: Add, Apply, Reset, Delete
- Close button: Close

Sample configuration CANopen-drive controller ref. to DS402

If a CANopen-drive controller ref. to profile DS402 is used, at least the controller-internal state machine must be managed by

- a 16-bit control word and

The Rx PDO Configuration dialog box shows the following settings:

- Setting: PDO Disable-Flag, RTR-not-allowed-flag, 29-bit-enable-flag
- COB ID: Konstant, "Node ID" + Offset (hex), gemäß CIA DS301
- Kommunikationsparameter: Download, Inhibit time [1/10 ms]: 100, Event time [ms]: 500, Übertragungstyp: 255
- S7 Mapping: Bereich: Datenblock, Blocknummer: 101, Byte-Offset: 0
- Mapping: Datenlänge (Bytes): 6, Zeige CAN-Objekte

Datentyp	Index (hex)	Sub index (hex)	Beschreibung
Word	6040	00	Controlword
Word	6060	00	Modes of Operation
Word	607A	00	Target Position
- Buttons: Hinzufügen, Übernehmen, Reset, Löschen, Schließen

- 16-bit status word

The Tx PDO Configuration dialog box shows the following settings:

- Setting: PDO Disable-Flag, RTR-not-allowed-flag, 29-bit-enable-flag
- COB ID: Konstant, "Node ID" + Offset (hex), gemäß CIA DS301
- Kommunikationsparameter: Download, Inhibit time [1/10 ms]: 100, Event time [ms]: 500, Übertragungstyp: 255
- S7 Mapping: Bereich: Datenblock, Blocknummer: 100, Byte-Offset: 0
- Mapping: Datenlänge (Bytes): 8, Zeige CAN-Objekte

Datentyp	Index (hex)	Sub index (hex)	Beschreibung
Word	6041	00	Statusword
Word	6061	00	Modes of Operation Display
Word	6100	01	DigitalInput
Word	603F	00	Error code
- Buttons: Hinzufügen, Übernehmen, Reset, Löschen, Schließen

(Images in German language but self explaining)

Assign these both words to S7-operands by the PDO-mapping and than the controller can be driven by the S7-program.

Onboard periphery of PC351V/P

Description

PC351V/P contains an onboard periphery as follows:

Standard configuration:

- 4 digital backreadable outputs 24V

INSEVIS-benefit DI/O:

Each single outputs can be switched off, so that you can realize different ratios of I/Os e.g. 1dI and 3dO or 3dI and 3dO. Only the total sum of I/Os must be ≤ 4 .

• 2 analog in- or outputs (software configurable)

Inputs:

- 0..10V, 0 (4)..20 mA
- 4..20 mA or +/- 20 mA for 4-wire-encoders

Outputs:

- 0..10V
- 0 (4)..20 mA

INSEVIS-benefit AI/O:

This module has an internal supply for the 2-wire encoders (4-20mA). So it is not necessary to care for external supply!

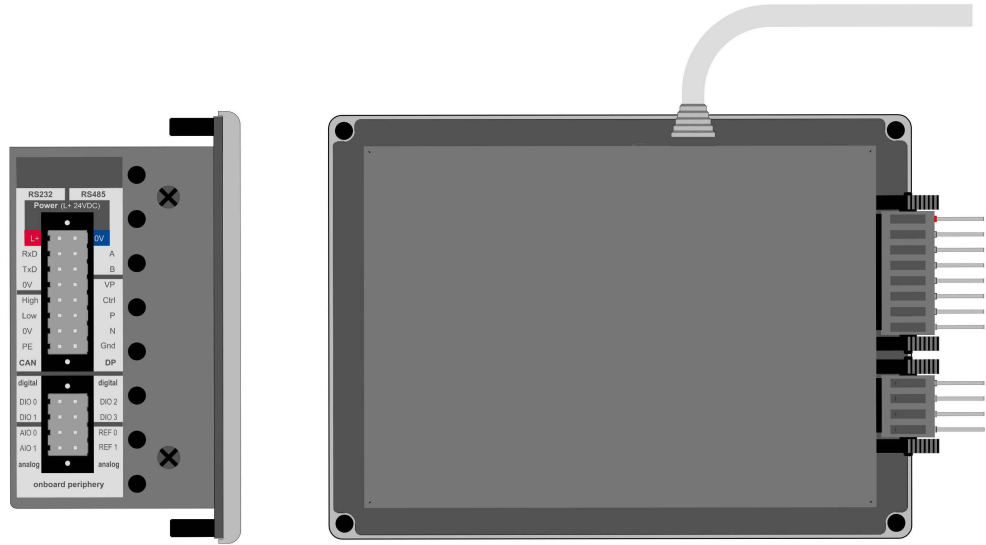

Figure above: Panel-PLC PC351V/P, rear view and view from the side

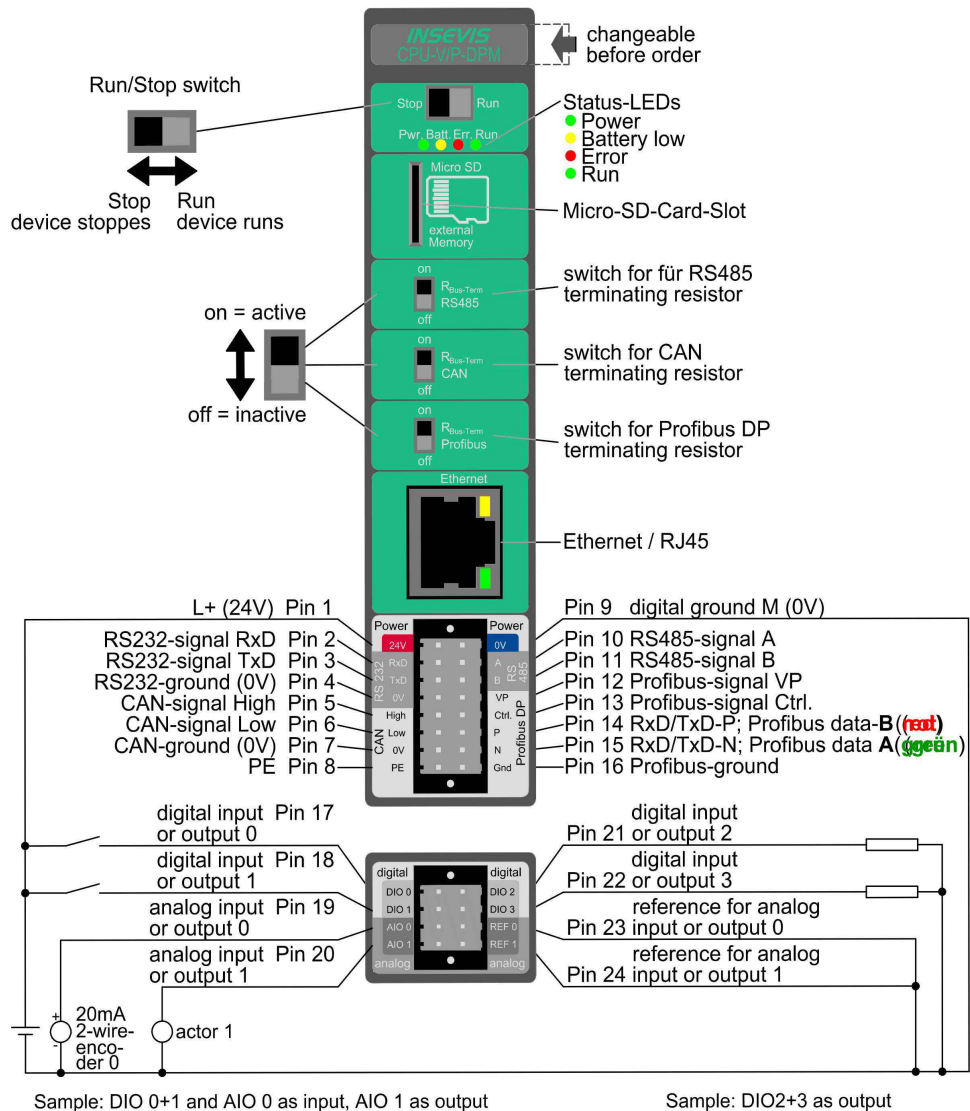

Figure above: Identification of CPU and onboard periphery of PC351V/P with Profibus DP Master

Onboard periphery of PC351V/P

Technical data	Device	
Dimensions W x H x D (mm) Cut out W x H (mm) Weight	132 x 96 x 49 118 x 89 ca. 450 g	
Operating temperature range Storage temperature range	-20°C ... +60°C (without condensation) -30°C ... +80°C	
IP-protection class front panel rear side	IP65 IP41	
Connection technology	cage clamp connector with lift-arms or bolt flanges on the sides (cage clamp technology) for cross section up to max. 1,5mm ²	
Load voltage L+	24V DC (11 V ... 30V DC)	
Current consumption Power dissipation	20 mA ... 350 mA 1,5 W (typ.), 4,2 W (max.)	
Start-up current	< 3A	
Diagonal of display (inch) Display resolution (pixel)	3,5" (89mm) 320x240 pixel (QVGA)	
Display unit Operating unit	TFT display with 16Bit colors analog resistive touch screen	
Visualization software Reference unit	VisuStage PC350	
Technical data	CPUs	
CPU-type	Type V (PC350V)	Type P (PC350P)
Working memory = battery backed load memory Diagnostic buffer	512kB, thereof 256 kByte remanent data 100 messages (all remanent)	640kB, thereof 384 kByte remanent data 100 messages (all remanent)
Flash internal - for visualization external memory	4 MByte Micro SD, up to max. 8 GByte	24 MByte Micro SD, up to max. 8 GByte
OB, FC, FB, DB Local data Number of in- and outputs Process image Number of Merkerbytes Number of Taktmerker Number of timer, counter Depth of nesting	each 1.024 32kByte (2kByte per block) in each case 2.048 Byte (16.384 Bit) adressable in each case 2.048 Byte (default set is 128 Byte) 2.048 (remanence adjustable, default set is 0..15) 8 (1 Merkerbyte) in each case 256 (each remanence adjustable, default set is 0) up to 16 code blocks	
Real-time clock elapsed hour counter	yes (accumulator-backed hardware clock) 1 (32Bit, resolution 1h)	
Program language Program system	STEP 7® - AWL, KOP, FUP, S7-SCL, S7-Graph from SIEMENS SIMATIC® Manager from SIEMENS or compatible products	
Operating system Program unit to reference	compatible to S7-300® from SIEMENS CPU 315-2PN DP	
Serial interfaces (protocols)	COM1: RS 232 (free ASCII) COM2: RS 485 (free ASCII, Modbus-RTU)	
Ethernet (protocols)	Ethernet: 10/100 Mbit with CP343 functionality (RFC1006, TCP, UDP, Modbus-TCP)	
CAN (protocols)	CAN-Telegramms (Layer 2), compatible to CANopen® MasterSlave 10 kBaud ... 1 MBaud	
Profibus (protocols)	Profibus DP V0 master/ slave 9,6kBaud ... 12 MBaud	
Decentral periphery	- INSEVIS- Periphery (with automatic configuration via „ConfigStage“) - all CANopen® Slaves according to DS401 - all Profibus DP-V0-Slaves - diverse external periphery families	

Onboard periphery of PC351V/P

Technical data		digital in-/ outputs	
Load voltage L+ Power dissipation	24V DC (10 V ... 30 V DC) internal limited	Wire length unshielded (max.) shielded (max.)	30 m 100 m
Digital in-/ outputs	4 outputs (each with backreadable input)	Outputs: Input delay Output delay Inputs: Input delay Output delay	50 µs (typ.) 30 µs (typ., without load) 25µs
Diagnostic LEDs	none		
Output current for signal 0 for signal 1	0,5 mA (max.) 0,5 A (max. to 60°C)	Max. switching frequency of outputs	100 Hz with ohmic load
Cumulated current	2 A (max. to 60°C)	Counter	2 counter with gate function or 2 incremental encoder
		Total frequency limit (Number of impulses of all 4 counting signals / s)	10 kHz
Broken wire detection Error diagnostic Potential separation to PLC	no no	Signal level of outputs for signal 0 for signal 1 Signal level of inputs for signal 0 for signal 1	1,0 V at 500 Ω (max.) L+ - 1,0 V at 0,5 A load (min.) 0V ... +5 V +7,5V ... +30 V

Block diagrams for digital in-/ outputs

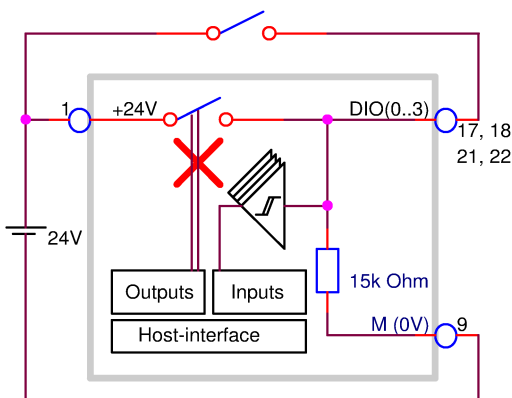

Block diagram of digital I/Os as input for 2-wire-encoders

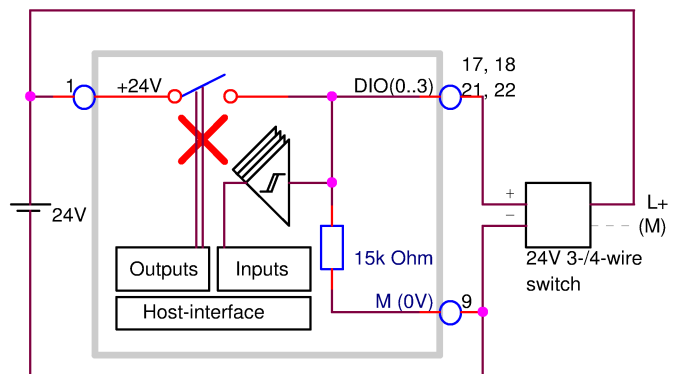

Block diagram of digital I/Os as input for 3/4-wire-encoders

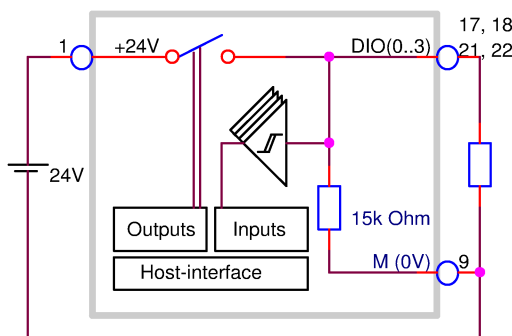

Block diagram of digital I/Os as backreadable output

General	
Input start address:	<input type="text" value="0"/>
Input end address:	<input type="text" value="31"/>
Output start address:	<input type="text" value="0"/>
Output end address:	<input type="text" value="31"/>
Digital	
Input address:	<input type="text" value="8"/>
Output address:	<input type="text" value="8"/>
Disable the output	
Channel 0.0	<input type="checkbox"/>
Channel 0.1	<input type="checkbox"/>
Channel 0.2	<input type="checkbox"/>
Channel 0.3	<input type="checkbox"/>

Configuration block of start-/ end addresses
(in Byte) and I/O parameterizing in the ConfigStage

Onboard periphery of PC351V/P

Configuration of the onboard counter inputs

Available at PC351V/P from 3/2015 in combination with ConfigStage version 1.0.14.15

Counter 1 (settings by ConfigStage)

Configuration „counting forward (up)“

→ rising edges will be counted at DI 0.0

Configuration „counting for- / backwards (down)“

→ rising edges will be counted at DI 0.0 and
→ DI 0.1 is used as direction bit (0=backwards, 1=forward)

Configuration „Encoder“

→ DI 0.0/ 0.1 with quadruple evaluation

Counter		
	Configuration	Address
Channel 1:	Count up	16
Channel 2:	Disabled	20

Disabled
 Count up
 Up/Down (Pulse/Dir)
 Encoder (x4)

Counter 2 (settings by ConfigStage)

Configuration „counting forward (up)“

→ rising edges will be counted at DI 0.2

Configuration „counting for- / backwards (down)“

→ rising edges will be counted at DI 0.2 and
→ DI 0.3 is used as direction bit (0=backwards, 1=forward)

Configuration „Encoder“

→ DI 0.2/ 0.3 with quadruple evaluation

Counter		
	Configuration	Address
Channel 1:	Count up	16
Channel 2:	Disabled	20

Disabled
 Count up
 Up/Down (Pulse/Dir)
 Encoder (x4)

Hints for usage of the onboard counter inputs

- read in counter by reading of ED16 / ED20 (synchronous to control point)
- set counter by writing to PAD16 / PAD20 (by direct periphery access only)
- this configuration can be modified in runtime with Step7 too:

Configuration word for counter 1 is PAW24

Configuration word for counter 2 is PAW28

“inactive”	0x00
“counting forward / up”	0x01
“for- / backward (pulse, direction)”	0x02
“encoder (x4)”	0x03

- all addresses are specified as offset relating to the configured start address

Onboard periphery of PC351V/P

Technical data	analog in-/ outputs		
Load voltage L+	24V DC (17 V ... 30 V DC) connected by device supply	Wire length unshielded (max.) shielded (max.)	30 m 100 m
Analog inputs Input areas	2 (alternatively to outputs what is to be configured by software) ±20 mA, 4...20 mA, 0..10 V	Valid voltage between inputs and A-GND (max.)	-1 V ... +24 V DC
Diagnostic LEDs	4 green: signal in valid area 4 red: override or saturation no displaying broken wires and open inputs	Error message during override metering area	adjustable diagnosis- and limit value alert on request
Value number format	9400 ... 6C00 (hexadecimal) for range ± 20 mA all other 0000 ... 6C00 (hexadecimal)	Broken wire detection	by overrun / shortfall of metering area
Override area	20 mA ... 22 mA 10V ... 11,3 V	Acces of sensor	unsymetric against A-GND (single ended)
Input resistance	0Ω (typ.) for metering area current 1MΩ (typ.) for metering area voltage	Metering priciple / conversion priciple Resolution	successive approximation 12 Bit
Sampling cycle time = Integration time	adjustable 1ms ... 35767 ms default: 100 ms (=line frequency filter 50Hz and 60Hz)	Specify (based on input area)	< 1%
Analog outputs Output area (nominal values)	2 (alternatively to inputs what is to be configured by software) 0(4)...20mA, 0...10V	Value number format	0000 ... 6C00 (hexadecimal)
Resolution	12 Bit	Short cut protection	yes
Diagnostic LEDs	none	Override area	20 ... 23 mA 10 ... 11,3 V
Setting time: response time τ (typ)	1,5 ms	Short cut current (typ.)	20 mA (at 10V) 32 mA (at mA)
Load resistance against A-GND	mA: 500 Ω (max.) V: 1 kΩ (min.)	Specify (based on output area)	< 1%

Configuration of the process image Module allocates 16 word process data input and output.			
Offset	I/O	Function	Description
0,2	I	Input AI0..AI1	Measuring range according to configuration
4,6	I	Reserved	
0,2	O	Output AO0..AO1	Measuring range according to configuration
4,6	O	Reserved	
8	I	Digital inputs .0 to .3	(Byte-access)
8	O	Digital outputs .0 to .3	(Byte-access)
10, 12,14	I/O	reserved	
16, 20	<u>I/O</u>	Counter 0 and 1	Counter value (DINT, DWORD access)
24,..31	I/O	Counter parameter	Configured by ConfigStage or FC's

Onboard periphery of PC351V/P

Block diagrams for analog in-/ outputs

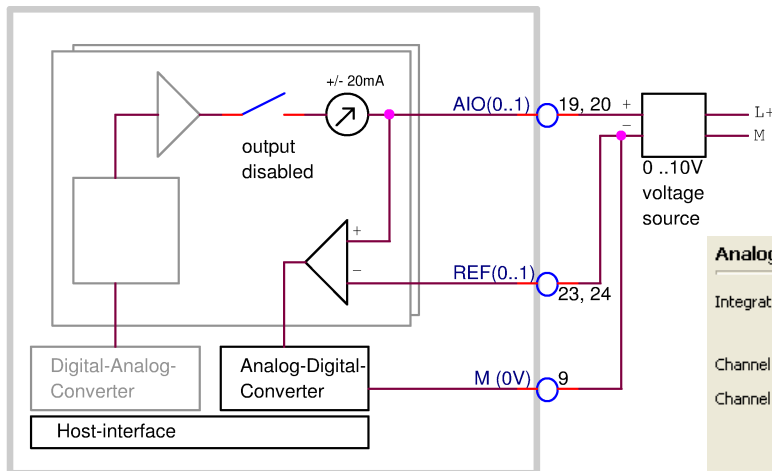

Block diagram for analog inputs for 0 .. 10 V

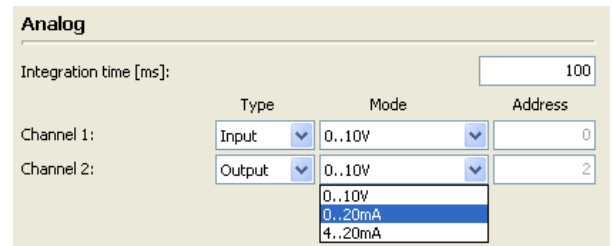

Configuration block of I/O-parameterizing in the ConfigStage

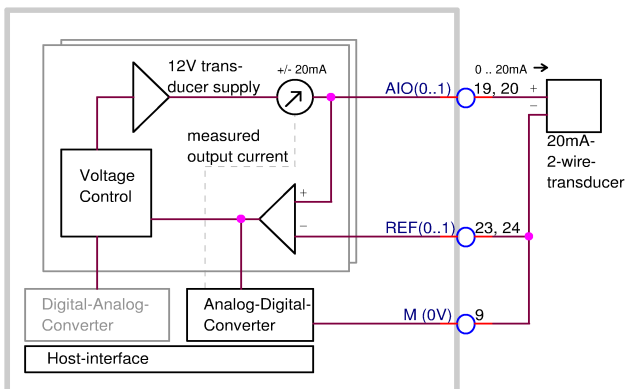

Block diagram for analog inputs for 20 mA with 2-wire-encoder

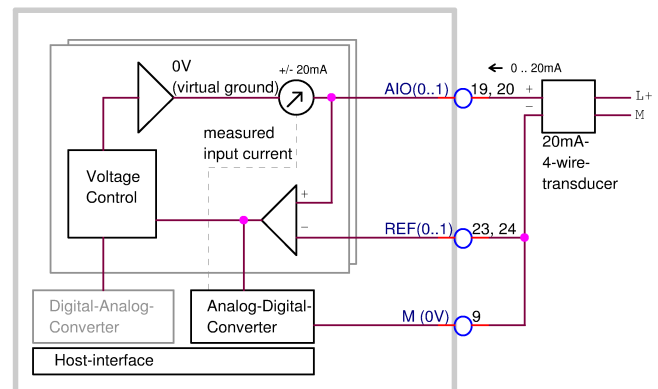

Block diagram for analog inputs for 20 mA with 3/4-wire-encoder

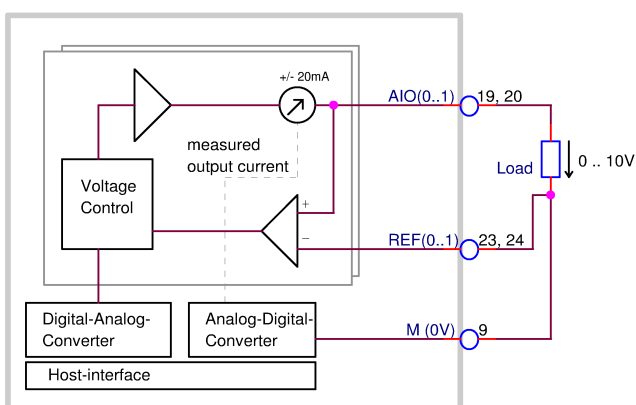

Block diagram for analog outputs for 10 V

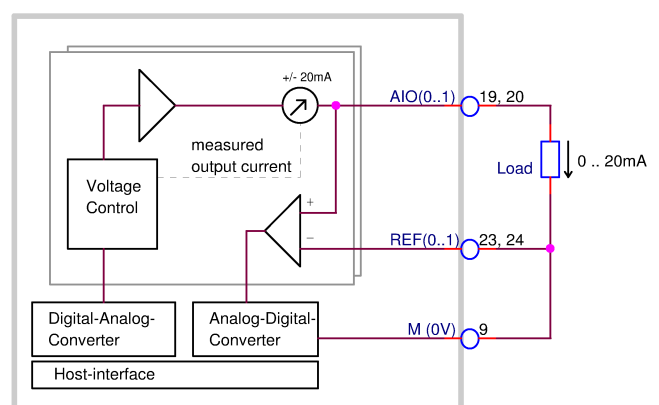

Block diagram for analog outputs for 20 mA

Periphery module DI16 (16 digital inputs 24V)

Description

compact periphery module for 16 digital inputs 24V

- green diagnostic LED for each input
- insertion stripe with description field for every signal

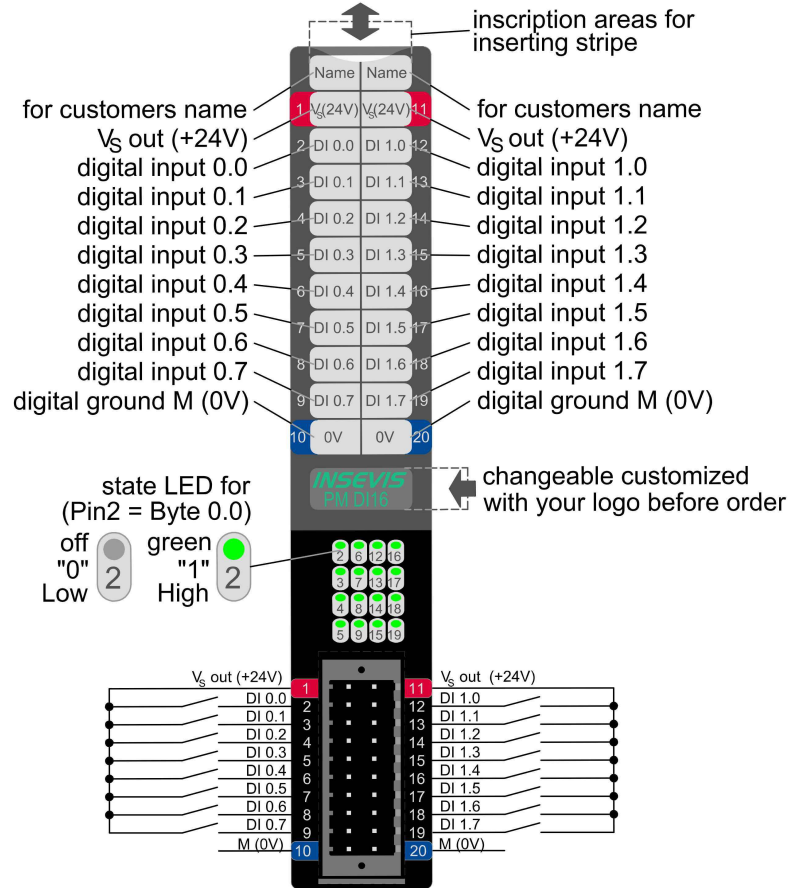

Figure above: Description and wiring of all connections of periphery module DI16

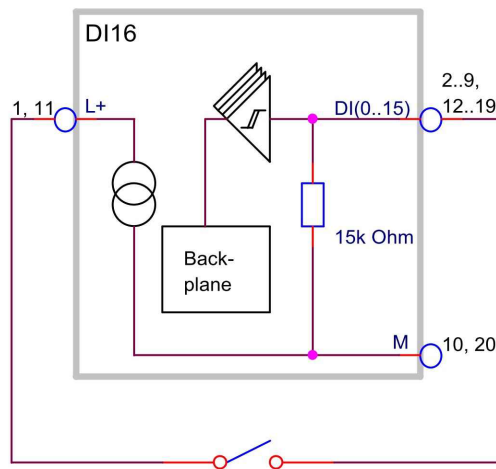

Figure above: Block diagram of DI16 for 2 wire switches

Input	
Start address:	<input type="text" value="0"/>
End address:	<input type="text" value="1"/>
Output	
Start address:	<input type="text" value="0"/>
End address:	<input type="text" value="0"/>

Figure above: Configuration block of start-/ end addresses of DI16-inputs (in byte) in the ConfigStage

Periphery module DI16 (16 digital inputs 24V)

Technical data	
Dimensions W x H x D (mm) Weight	20 x 108 x 70 mm ca. 150 g
Operating temperature range Storage temperature range	-20°C ... +60°C (no condensation) -30°C ... +80°C
Connection technology	cage clamp connector with lift-arms or bolt flanges on the sides (cage clamp technology) for cross section up to max. 1,5mm ²
Sensor supply Load voltage L+	short circuit proof output, current limited to 30 mA (typ.) 24V DC (11V ... 30V DC, is connected by device supply)
Wire length unshielded (max.) shielded (max.)	30 m 100 m
Digital inputs Diagnostic LEDs	16 16, green
Input voltage for signal 0 for signal 1	0V ... +5 V +7,5V ... +30 V
Input current for signal 1	1 mA
Broken wire detection Potential separation to PLC Access of 2-wire-BERO	no no no
Input delay Output delay Sampling cycle time	90 µs (typ.) 1,4 ms (typ.) as onboard modul on the PLC = cycle synchronous

Periphery module DIO16 (16 digital in- or outputs 24V)

Description

compact periphery module for **16 digital transistor outputs 24V with back-readable inputs**

- green diagnostic LED for each in-/ output
- insertion stripe with description field for every signal
- **Scope of delivery:**
 - technical information
 - brief instruction

Notice: more wiring samples are shown in the technical information sheets at the periphery modules in the web.

INSEVIS-benefit: Each single outputs can be switched off, so that you can realize different ratios of I/Os e.g. 10dI and 6dO or 7dI and 9dO. Only the total sum of I/Os must be ≤16.

Attention: L+supplies of the outputs are separated for each byte (left and right).
 → At a use as outputs only all these outputs can be switched off together by switching off the L+ supply of this byte.
 → If there are used some of these bits as inputs, they may not have applied a voltage (24V) while switching off.

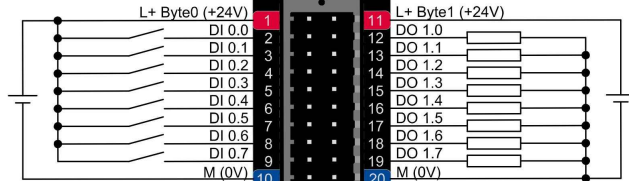
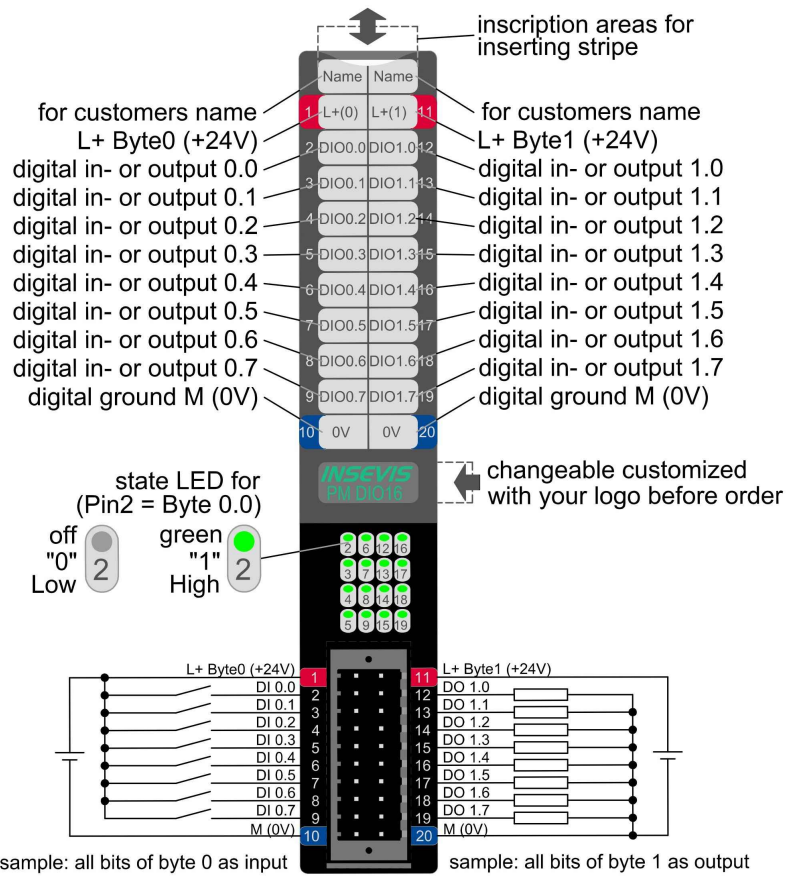

Figure above: Description and wiring of DIO16 for 2-wire switches

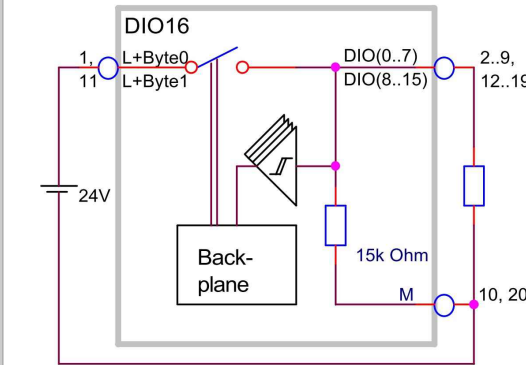

diagram of DIO16 (as backreadable output)

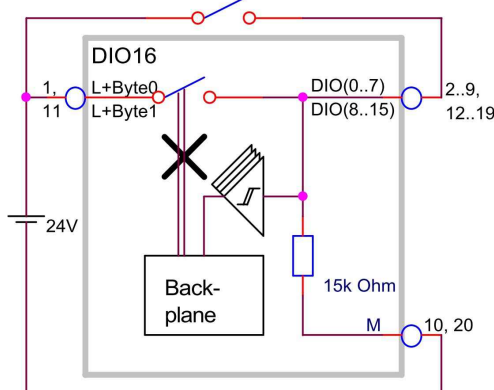

Figure above: Block diagram of DIO16 (as input only)

Input	
Start address:	0
End address:	1
Output	
Start address:	0
End address:	1
Mode	
	Disable the output
Channel 0.0	<input checked="" type="checkbox"/>
Channel 0.1	<input checked="" type="checkbox"/>
Channel 0.2	<input checked="" type="checkbox"/>
Channel 0.3	<input checked="" type="checkbox"/>
Channel 0.4	<input checked="" type="checkbox"/>
Channel 0.5	<input checked="" type="checkbox"/>
Channel 0.6	<input checked="" type="checkbox"/>
Channel 0.7	<input checked="" type="checkbox"/>
Channel 1.0	<input type="checkbox"/>
Channel 1.1	<input type="checkbox"/>
Channel 1.2	<input type="checkbox"/>
Channel 1.3	<input type="checkbox"/>
Channel 1.4	<input type="checkbox"/>
Channel 1.5	<input type="checkbox"/>
Channel 1.6	<input type="checkbox"/>
Channel 1.7	<input type="checkbox"/>

Figure above: configuration block of DIO16 in-/outputs (in byte) in the ConfigStage

Periphery module DIO16 (16 digital in- or outputs 24V)

Description

compact periphery module for **16 digital transistor outputs 24V with back-readable inputs**

- green diagnostic LED for each in-/ output
- insertion stripe with description field for every signal

- **Scope of delivery:**
 - technical information
 - brief instruction

INSEVIS-benefit:

Each single outputs can be switched off, so that you can realize different ratios of I/Os e.g. 10dI and 6dO or 7dI and 9dO. Only the total sum of I/Os must be ≤ 16 .

Attention:

L+supplies of the outputs are separated for each byte (left and right).
 → At a use as outputs only all these outputs can be switched off together by switching off the L+ supply of this byte.
 → If there are used some of these bits as inputs, they may not have applied a voltage (24V) while switching off.

Application with 3- or 4-wire switches

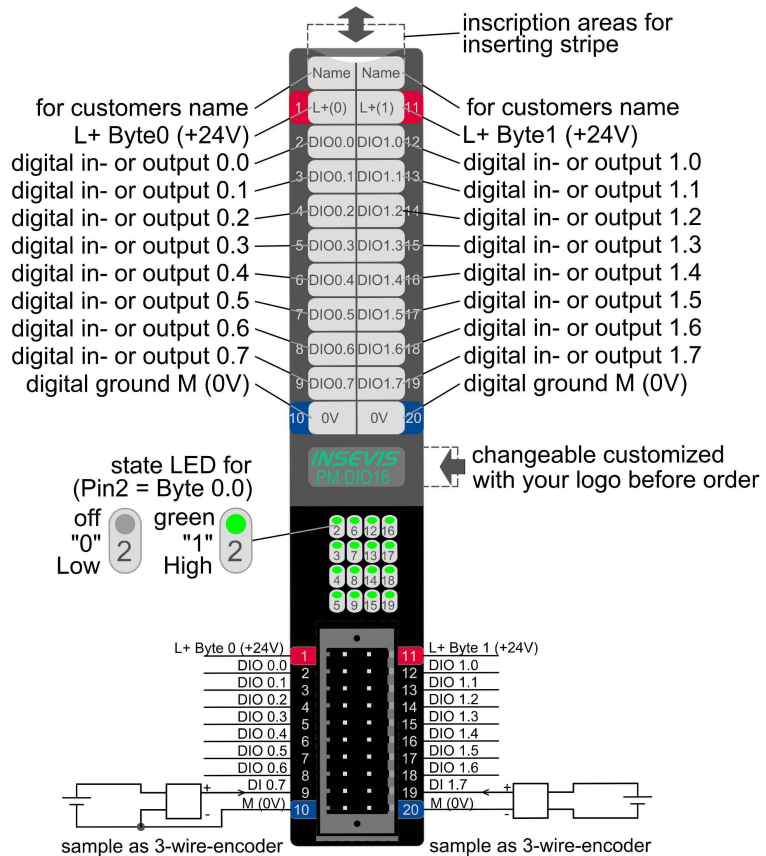

above: Description and wiring of DIO16 for 3-/ 4-wire switches

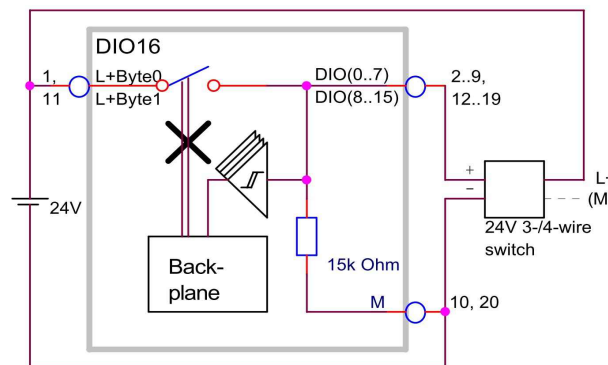

Block diagram of DIO16 for 3- or 4-wire switches

Input	
Start address:	0
End address:	1
Output	
Start address:	0
End address:	1
Mode	
Disable the output	
Channel 0.0	<input type="checkbox"/>
Channel 0.1	<input type="checkbox"/>
Channel 0.2	<input type="checkbox"/>
Channel 0.3	<input type="checkbox"/>
Channel 0.4	<input type="checkbox"/>
Channel 0.5	<input type="checkbox"/>
Channel 0.6	<input type="checkbox"/>
Channel 0.7	<input checked="" type="checkbox"/>
Channel 1.0	<input type="checkbox"/>
Channel 1.1	<input type="checkbox"/>
Channel 1.2	<input type="checkbox"/>
Channel 1.3	<input type="checkbox"/>
Channel 1.4	<input type="checkbox"/>
Channel 1.5	<input type="checkbox"/>
Channel 1.6	<input type="checkbox"/>
Channel 1.7	<input checked="" type="checkbox"/>

configuration block of DIO16 -in-/outputs (in byte) in the ConfigStage

Periphery module DIO16 (16 digital in- or outputs 24V)

Technical data			
Dimensions W x H x D (mm) Weight	20 x 108 x 70 mm ca. 150 g		
Operating temperature range Storage temperature range	-20°C ... +60°C (without condensation) -30°C ... +80°C		
Connection technology	cage clamp connector with lift-arms or bolt flanges on the sides (cage clamp technology) for cross section up to max. 1,5mm ²		
Load voltage L+ Current consumption Power dissipation	10 V ... 30 V DC 50 mA (without load) internal limited		
Wire length unshielded (max.) shielded (max.)	30 m 100 m		
Digital in-/ outputs Diagnostic LEDs	16 in- or outputs (adjustable by software) 16, green		
Output current for signal 0 for signal 1 Cumulated current per output-byte	0,5 mA (max.) 0,5 A (max. bis 60°C) 3 A (max. bis 60°C)	Input current for signal 1	1 mA (typ.)
Signal level of outputs for signal 0 for signal 1	1,0 V at 500 Ω (max.) L+ - 1,0 V at 0,5 A load (min.)	Input voltage for signal 0 for signal 1	0V ... +5 V +7,5V ... +30 V
Input delay Output delay	50 μs (typ.) 30 μs (typ., without load)	Input delay Output delay Sampling cycle time	1,5 ms (typ.) 4,6 ms (typ.) synchronous to cycle
Max. switching frequency with ohmic load	100 Hz		
Broken wire detection Error diagnostic Potential separation to PLC		no no	

Periphery module DO4-R (4 relay outputs 230V)

Description

compact periphery module
for 4 relay outputs 230V AC

- 4 potential separated contacts
- 4 glass bulb fuses 5x20mm (1 for each relay)
- insertion stripe for 2 name fields
- green diagnostic LED for each output
- screwed contact connector

Note:
Because of the fuses position this module is to be placed in the 3 very right slots only..

(Other positions are more than 3 modules possible on request.)

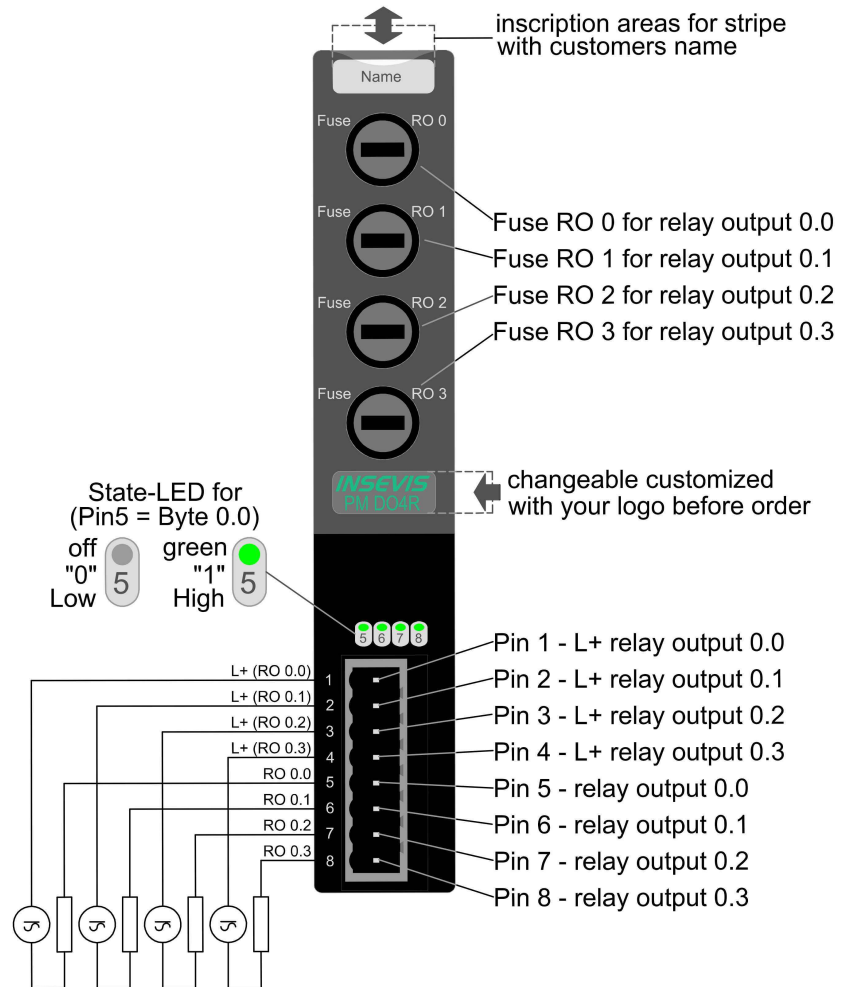

Figure above: Description and wiring of all connections of periphery module DO4-R

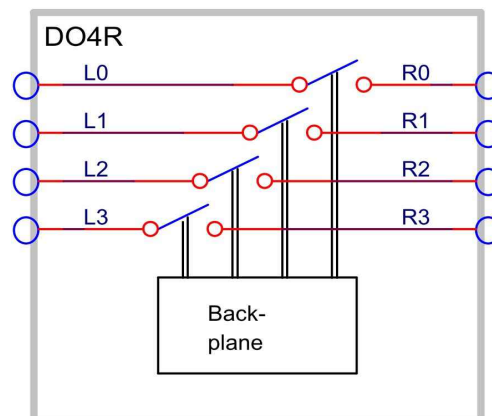

Figure above: Block diagram of DO4-R

Input	
Start address:	<input type="text" value="0"/>
End address:	<input type="text" value="0"/>
Output	
Start address:	<input type="text" value="8"/>
End address:	<input type="text" value="8"/>

Figure above: Configuration block of start-/end addresses of DO4-R (in byte) in the ConfigStage

Periphery module DO4-R (4 relay outputs 230V)

Technical data	
Dimensions W x H x D (mm) Weight	20 x 108 x 70 mm ca. 150 g
Operating temperature range Storage temperature range	-20°C ... +60°C (without condensation) -30°C ... +80°C
Connection technology	screw connector for cross section up to max. 1,5mm ²
Load voltage L+ Load voltage L+ on the relay Current consumption Power dissipation	24 V (17 V ... 30 V, connected by device supply) 30 V DC (max.), 250 V AC (max.) 45 mA aus L+ (max.) 0,8 W bei 24V (max.)
Wire length unshielded (max.) shielded (max.)	30 m 100 m
Digital outputs Diagnostic LEDs	4 4, green
Topography	4 potential separated contacts
Input delay Output delay	5 ms ... 10 ms (typ.) 2 ms ... 5 ms (typ.)
Switching capacity of contacts at inductive load at ohmic load	3A (max.) 3A (max.)
Max. switching frequency mechanical with load	50 Hz 5 Hz
Type number of switching operations mechanical with 3A	20Mio 100.000
Broken wire detection Error diagnostic Potential separation to PLC Short circuit proof	no no yes yes - melting fuse in glass bulbs 5x20mm

Periphery module MIO84 (8 digital I/O with counter + 4 analog I/O)

Description

compact periphery module for

8 digital transistor outputs 24V with back-readable inputs

- green diagnostic LED for each in-/ output
- insertion stripe with description field for every signal
- cage-clamp connector with self-lock and 2 lift arms
- **Scope of delivery:**
 - technical information
 - brief instruction

INSEVIS-benefit:

Each single outputs can be switched off, so that you can realize different ratios of I/Os e.g. 6dI and 2dO or 3dI and 5dO. Only the total sum of I/Os must be ≤ 8 .

for digital signals (2- and 3-/4-wire-switches)

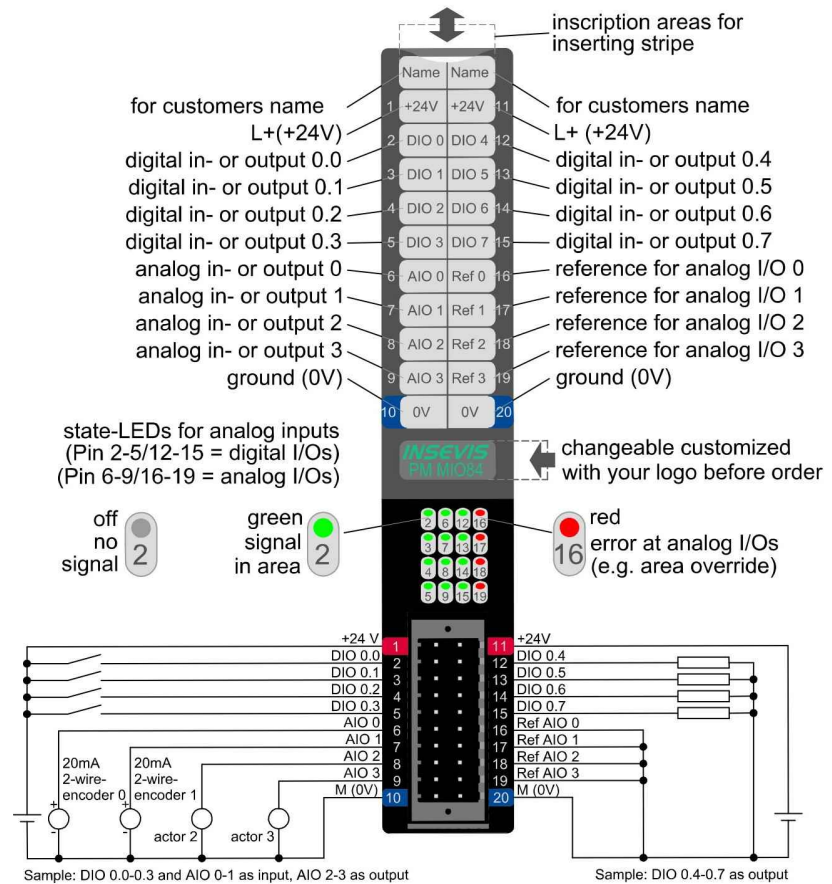

above: Description and wiring of MIO84 for 2-wire switches

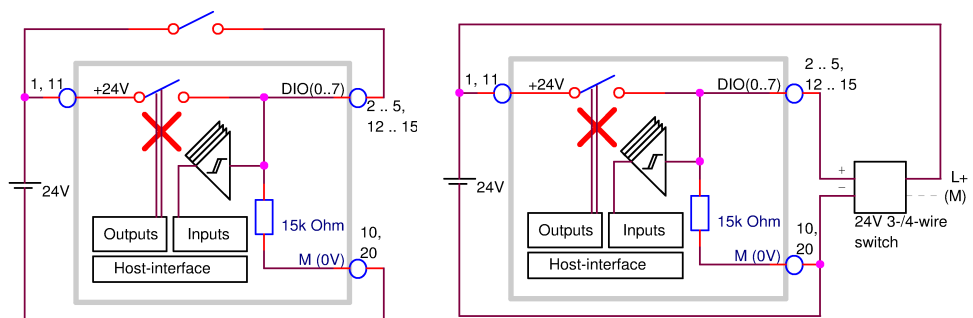

above: Block diagram of digital inputs for 2-wire-switches (left) and 3-/4-wire-switches (right)

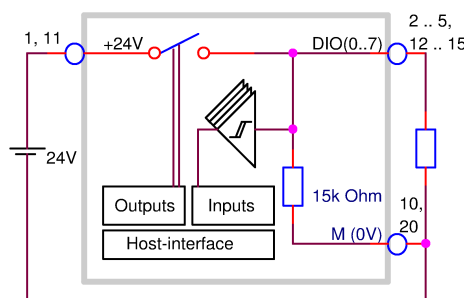

above: Block diagram of backreadable outputs

Digital	Input address	Output address
	Disable the output	
Channel 0.0	16.0	<input checked="" type="checkbox"/>
Channel 0.1	16.1	<input checked="" type="checkbox"/>
Channel 0.2	16.2	<input type="checkbox"/>
Channel 0.3	16.3	<input type="checkbox"/>
Channel 0.4	16.4	<input checked="" type="checkbox"/>
Channel 0.5	16.5	<input type="checkbox"/>
Channel 0.6	16.6	<input type="checkbox"/>
Channel 0.7	16.7	<input type="checkbox"/>

above: Configuration block of I/O-parametrizing in the ConfigStage

Periphery module MIO84 (8 digital I/O with counter + 4 analog I/O)

Description

for analog inputs (2-wire-encoders)

- 4 analog in- or outputs configurable by software

Inputs:
 - 0..10V, 0 (4)..20 mA for 2-wire-encoders including encoder supply
 - 4..20 mA or ± 20 mA for 4-wire-encoders

Outputs:
 - 0..10V
 - 0 (4)..20 mA

• Resolution 12 ...16 Bit (depending on integration time)

• green diagnostic-LEDs
 - LED 6 for A I/O 0
 - LED 7 for A I/O 1
 - LED 8 for A I/O 2
 - LED 9 for A I/O 3

• red diagnostic-LEDs for errors (override or short circuit on AI)
 - LED 16 for A I/O 0
 - LED 17 for A I/O 1
 - LED 18 for A I/O 2
 - LED 19 for A I/O 3

• insertion stripe with description field for every signal

• cage-clamp connector with self-lock and 2 lift arms

• **Scope of delivery:**
 - technical information
 - brief instruction

Hint:
 Connect Ref AIO 0..3 with ground (0V) always

INSEVIS-benefit:
 This module has an internal supply for the 2-wire encoders. So it is not necessary to care for external supply!

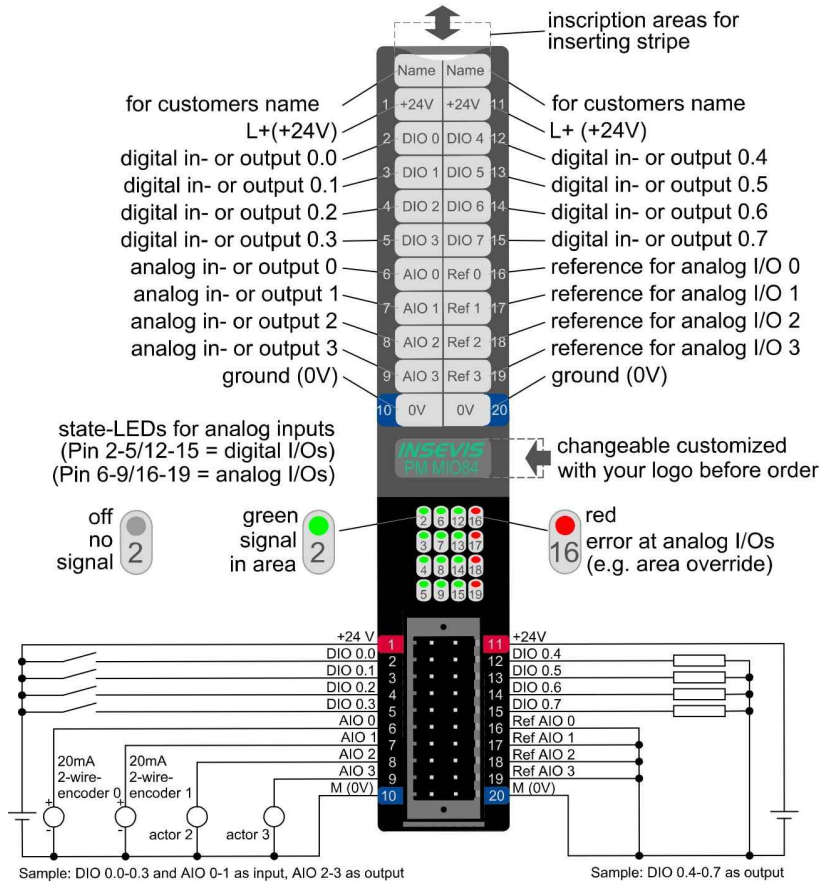

above: Description and wiring of all connections of PM MIO84 with 2-wire encoders

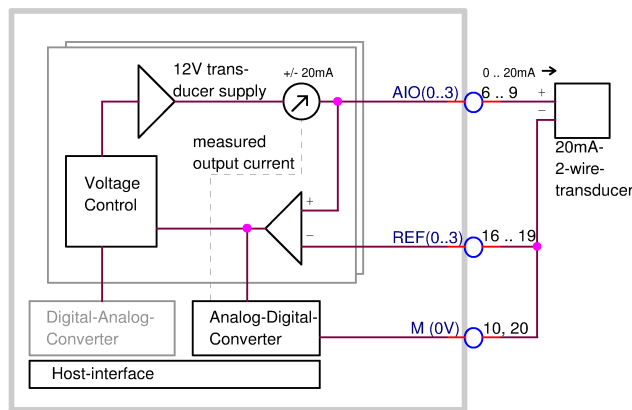

above: Block diagram for 2-wire-encoders (0..20mA)

Analog			
Integration time [ms]:			
			4
Channel	Type	Mode	Address
Channel 1:	Input	0..10V	8
Channel 2:	Input	4..20mA (2-wire)	10
Channel 3:	Output	0..10V	12
Channel 4:	Output	4..20mA	14

above: Configuration block of I/O-parametrizing in the ConfigStage

Periphery module MIO84 (8 digital I/O with counter + 4 analog I/O)

Description

- 4 analog in- or outputs configurable by software

Inputs:

- 0..10V, 0 (4)..20 mA for 2-wire-encoders including encoder supply
- 4..20 mA or ± 20 mA for 4-wire-encoders

Outputs:

- 0..10V
- 0 (4)..20 mA

- Resolution 12 ...16 Bit (depending on integration time)

- green diagnostic-LEDs
 - LED 6 for A I/O 0
 - LED 7 for A I/O 1
 - LED 8 for A I/O 2
 - LED 9 for A I/O 3

- red diagnostic-LEDs for errors (override or short circuit on AI)
 - LED 16 for A I/O 0
 - LED 17 for A I/O 1
 - LED 18 for A I/O 2
 - LED 19 for A I/O 3

- insertion stripe with description field for every signal

- cage-clamp connector with self-lock and 2 lift arms

• Scope of delivery:

- technical information
- brief instruction

Hint:

Connect Ref AIO 0..3 with ground (0V) always

for analog inputs (3-/4-wire-encoders)

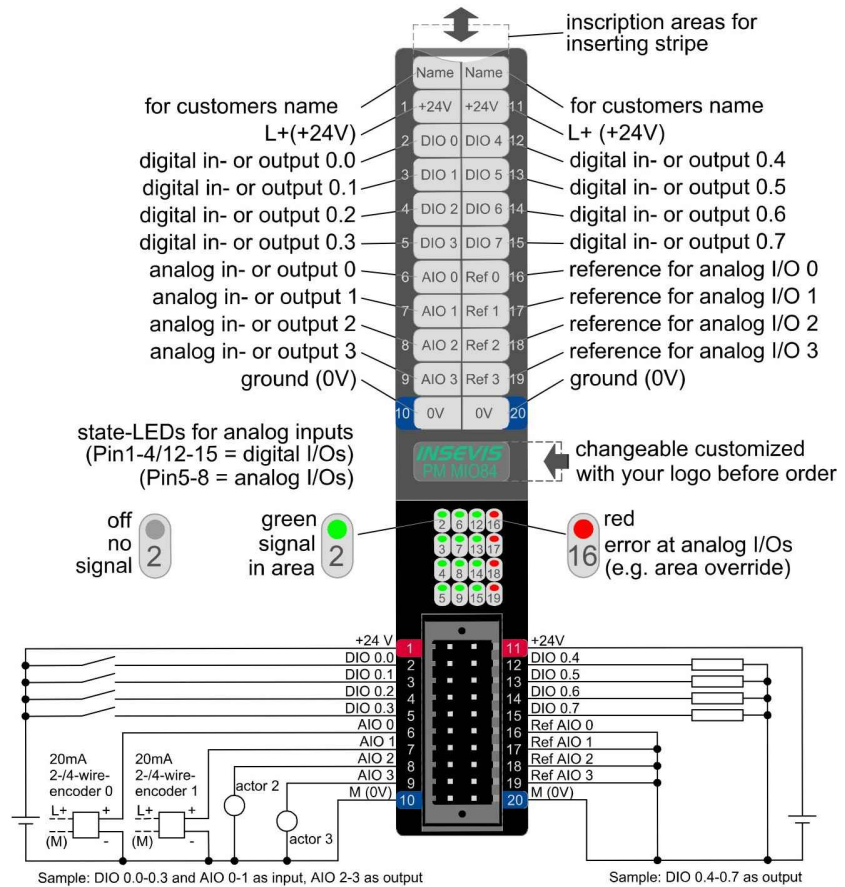

above: Description and wiring of all connections of PM MIO84 with 3-/4-wire encoders

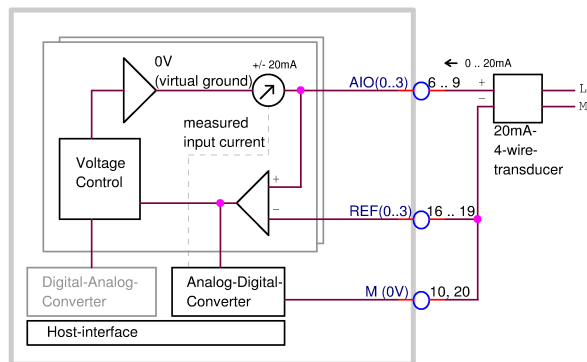

left: Block diagram for 3-/4-wire encoders (0...20mA)

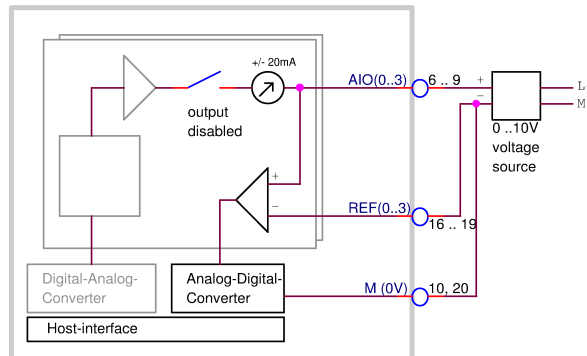

left: Block diagram for 3-/4-wire encoders (0...10V)

Periphery module MIO84 (8 digital I/O with counter + 4 analog I/O)

Description

- 4 analog in- or outputs configurable by software

Inputs:
 - 0..10V, 0 (4)..20 mA for 2-wire-encoders including encoder supply
 - 4..20 mA or ± 20 mA for 4-wire-encoders
 Outputs:
 - 0..10V
 - 0 (4)..20 mA

• Resolution 12 ... 16 Bit (depending on integration time)

• green diagnostic-LEDs
 - LED 6 for A I/O 0
 - LED 7 for A I/O 1
 - LED 8 for A I/O 2
 - LED 9 for A I/O 3

• red diagnostic-LEDs for errors (override or short circuit on AI)
 - LED 16 for A I/O 0
 - LED 17 for A I/O 1
 - LED 18 for A I/O 2
 - LED 19 for A I/O 3

• insertion stripe with description field for every signal

• cage-clamp connector with self-lock and 2 lift arms

• **Scope of delivery:**
 - technical information
 - brief instruction

Hint:
 Connect Ref AIO 0..3 with ground (0V) always

for analog outputs

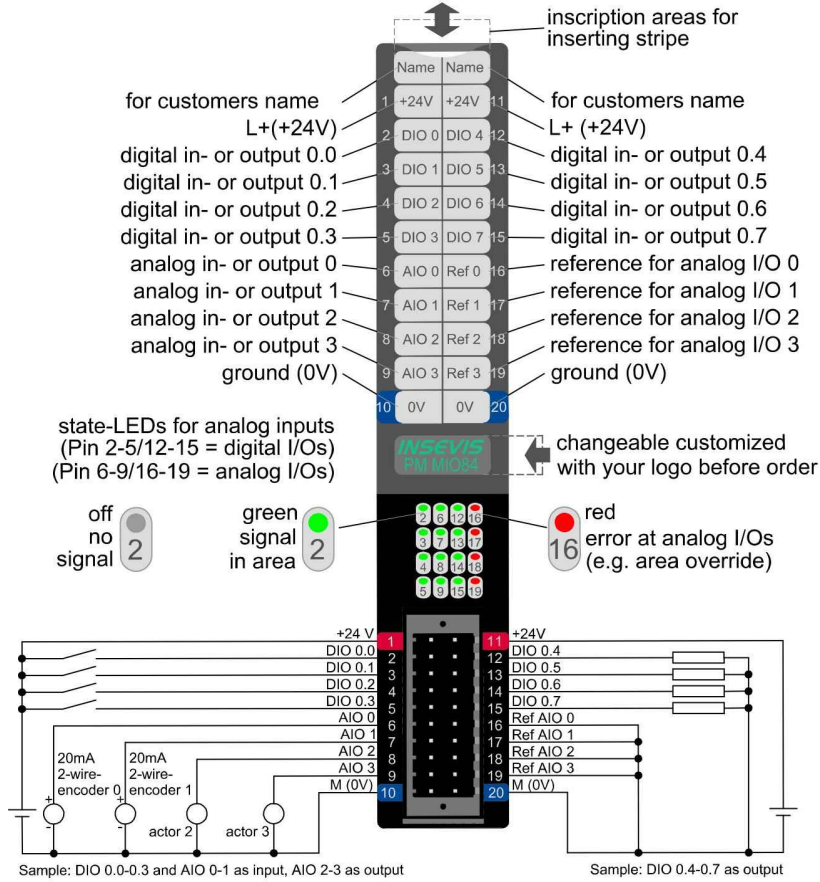

above: Description and wiring of all connections of PM MIO84 for analog outputs

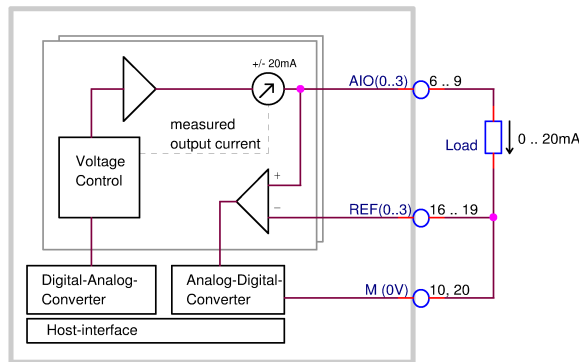

left: Block diagram for analog outputs (0...20mA)

left: Block diagram for analog outputs (0...10V)

Periphery module MIO84 (8 digital I/O with counter + 4 analog I/O)

Configuration of the counter inputs

Counter 1 (settings by ConfigStage)

Configuration „counting forward (up)“

→ rising edges will be counted at DI 0.0

Configuration „counting for- / backwards (down)“

→ rising edges will be counted at DI 0.0 and
→ DI 0.1 is used as direction bit (0=backwards, 1=forward)

Configuration „Encoder“

→ DI 0.0/ 0.1 with quadruple evaluation

Counter		
	Configuration	Address
Channel 1:	Count up	16
Channel 2:	Count up	20
	Up/Down (Pulse/Dir)	
	Encoder (x4)	

Counter 2 (settings by ConfigStage)

Configuration „counting forward (up)“

→ rising edges will be counted at DI 0.2

Configuration „counting for- / backwards (down)“

→ rising edges will be counted at DI 0.2 and
→ DI 0.3 is used as direction bit (0=backwards, 1=forward)

Configuration „Encoder“

→ DI 0.2/ 0.3 with quadruple evaluation

Counter		
	Configuration	Address
Channel 1:	Count up	16
Channel 2:	Disabled	20
	Up/Down (Pulse/Dir)	
	Encoder (x4)	

Hints for usage of the counter inputs

- all addresses are specified as offset relating to the configured start address

onboard:

- read in counter by reading of ED16 / ED20 (synchronous to control point)
- set counter by writing to PAD16 / PAD20 (by direct periphery access only)
- this configuration can be modified in runtime with Step7 too:

Configuration word for counter 1 is PAW24

Configuration word for counter 2 is PAW28

“inactive”	0x00
“counting forward / up”	0x01
“for- / backward (pulse, direction)”	0x02
“encoder (x4)”	0x03

decentral:

- read in counter by reading of ED12 / ED16 (synchronous to control point)
- Direct periphery access is implemented for decentral periphery only for data which are mapped into the process image. To set counters or write configuration use CANopen objects via SDO access.

Configuration word for counter 1	object index 0x3010 + slot-1, subindex 6
Configuration word for counter 2	object index 0x3010 + slot-1, subindex 7
setpoint counter 1 (dw)	object index 0x3100 + slot-1, subindex 1
setpoint counter 2 (dw)	object index 0x3100 + slot-1, subindex 2

Periphery module MIO84 (8 digital I/O with counter + 4 analog I/O)

Technical data	digital in-/ outputs		
Load voltage L+ Power dissipation	24V DC (10 V ... 30 V DC) internal limited	Wire length unshielded (max.) shielded (max.)	30 m 100 m
Digital in- / outputs	8 in- or outputs	Outputs: switch on delay switch off delay	50 μ s (typ.) 30 μ s (typ., without load)
Diagnostic LEDs	8, green	Inputs: switch on delay switch off delay	25 μ s
Output current for signal 0 for signal 1	0,5 mA (max.) 0,5 A (max. to 60°C)	Max. switching frequency of outputs	100 Hz with ohmic load
Cumulated current	2 A (max. to 60°C)	Counter	2 each as forward counter, forward/backward counter or incremental encoder 10 kHz
Broken wire detection Error diagnostic Potential separation to PLC	no no	Signal level of outputs for signal 0 for signal 1 Signal level of inputs for signal 0 for signal 1	1,0 V at 500 Ω (max.) L+ - 1,0 V at 0,5 A load (min.) 0V ... +5 V +7,5V ... +30 V

Technical data	analog in-/ outputs		
Load voltage L+	24V DC (17 V ... 30 V DC) connected by device supply	Wire length unshielded (max.) shielded (max.)	30 m 100 m
Analog inputs	4 (alternatively to outputs what is to be configured by software)	Valid voltage between inputs and A-GND (max.)	-1 V ... +24 V DC
Input areas	\pm 20 mA, 4...20 mA, 0..10 V	Error message during override metering area	adjustable diagnosis- and limit value alert on request
Diagnostic LEDs	4 green: signal in valid area 4 red: override or saturation no displaying broken wires and open inputs	Broken wire detection	by overrun / shortfall of metering area
Value number format	9400 ... 6C00 (hexadecimal) for range \pm 20 mA all other 0000 ... 6C00 (hexadecimal)	Acces of sensor	unsymetric against A-GND (single ended)
Override area	20 mA ... 22 mA 10V ... 11,3 V	Metering priciple / conversion priciple Resolution	successive approximation 12...16Bit (depending on integration time assigned in ConfigStage)
Imput resitance	0 Ω (typ.) for metering area current 1M Ω (typ.) for metering area voltage	Deviation (based on input area)	< 1%
Sampling cycle time = Integration time	adjustable 1ms ... 35767 ms default: 100 ms (=line frequency filter 50Hz and 60Hz)	Value number format	0000 ... 6C00 (hexadecimal)
Analog outputs	4 (alternatively to inputs what is to be configured by software)	Short cut protection	yes
Output area (nominal values)	0(4)...20 mA, 0...10V	Override area	20 ... 23 mA 10 ... 11,3 V
Resolution	15 Bit $\Sigma\Delta$ -Modulation	Short cut current (typ.)	20 mA (at 10V) 32 mA (at mA)
Diagnostic LEDs	4 green: signal in valid area 4 rot: override or Load error	Deviation (based on output area)	< 1%
Setting time: response time τ (typ)	1,5 ms		
Load resistance against A-GND	mA: 500 Ω (max.) V: 1 k Ω (min.)		

Periphery module MIO84 (8 digital I/O with counter + 4 analog I/O)

Process image for onboard use

Configuration of the process image onboard: module allocates 24 bytes of process data input and output.			
Offset	I/O	Function	Description
0, 2, 4, 6	I	Input AI 0..AI 3	Measuring range according to configuration - in voltage output mode: measure of output current - in current output mode: measure of output voltage
0, 2, 4, 6	O	Output AO0..AO 3	Measuring range according to configuration - in input mode: ignored
8	I	Digital inputs .0 to .7	(Byte access)
8	O	Digital outputs .0 to .7	(Byte access)
9 ... 15	I/O	Reserved	
16, 20	I/O	Counter 0, 1	Counter value (DINT, DWORD access)

Process image for decentral use

Configuration of the process image as decentral periphery: module allocates 20 bytes of process data input and 9 bytes of process data output.			
Offset	I/O	Function	Description
0, 2, 4, 6	I	Input AI 0..AI 3	Measuring range according to configuration
0, 2, 4, 6	O	Output AO0..AO 3	Measuring range according to configuration
8	I	Digital inputs .0 to .7	(Byte access)
8	O	Digital outputs .0 to .7	(Byte access)
9 ... 11	I	Reserved	
12,16	I	Counter 0, 1	Counter value (DINT, DWORD access)

Periphery module AI4O4 (4 analog in- and 4 analog outputs)

Description

compact periphery module for

- 4 analog inputs to be configured by software
 0...20mA, 4...20mA,
 0...10 V, ±10V, ±5V, ±2,5V

4 analog outputs to be configured by software
 ± 20mA, 4...20mA, ±10V

- Resolution 12 Bit
- green diagnostic LED for each input
 - LED 1 for AI0
 - LED 2 for AI1
 - LED 3 for AI2
 - LED 4 for AI3
 - LED 5 for AO0
 - LED 6 for AO1
 - LED 7 for AO2
 - LED 8 for AO3
- red diagnostic LED for each input for error (sensor-/ broken wire detection)
 - LED 1 for AI0
 - LED 2 for AI1
 - LED 3 for AI2
 - LED 4 for AI3
 - (or output error flag)
 - LED 5 for AO0
 - LED 6 for AO1
 - LED 7 for AO2
 - LED 8 for AO3
- Increase of the resolution of analog inputs by expanding the integration time up to 16Bit
- insertion stripe with description field for every signal

INSEVIS-benefit:

This module has an internal supply for the 2-wire encoders (4-20mA). So it is not necessary to care for external supply!

If you use these pins 1-4, do not apply external encoder supply!

Always connect Ref0..3 with analog ground (0V)

for 2-wire encoders

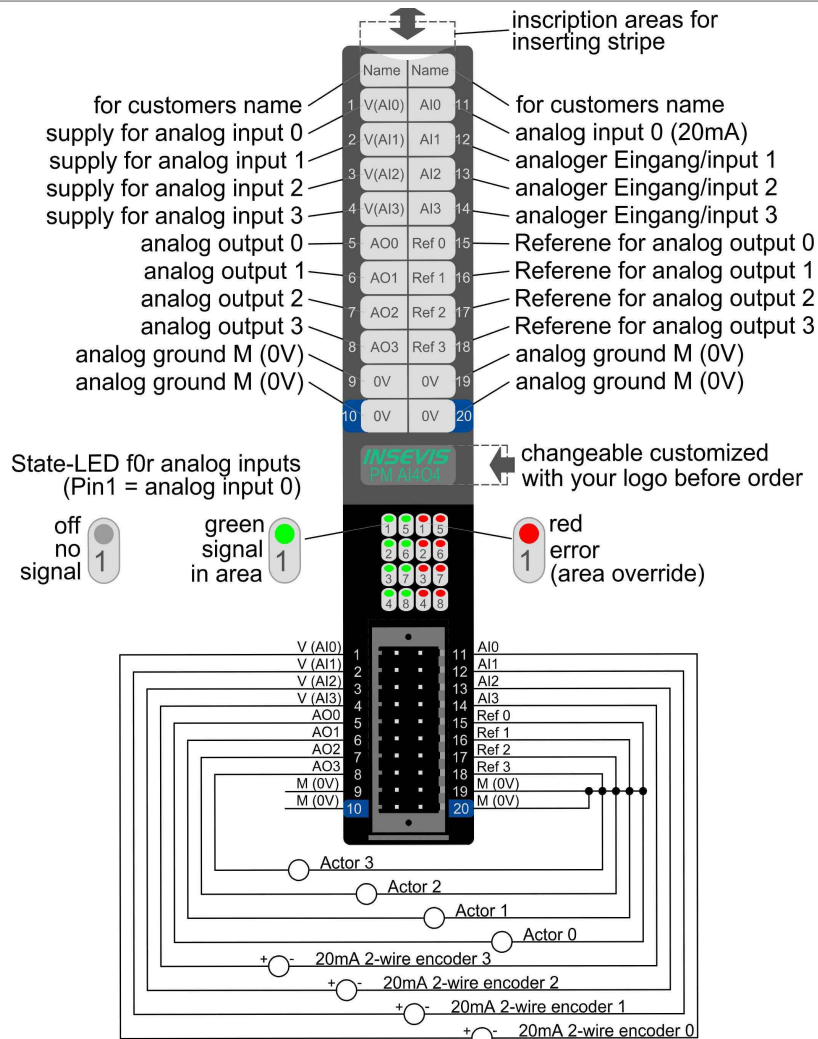

Figure above: Description and wiring of all connections of PM AI4O4 with 2-wire encoders

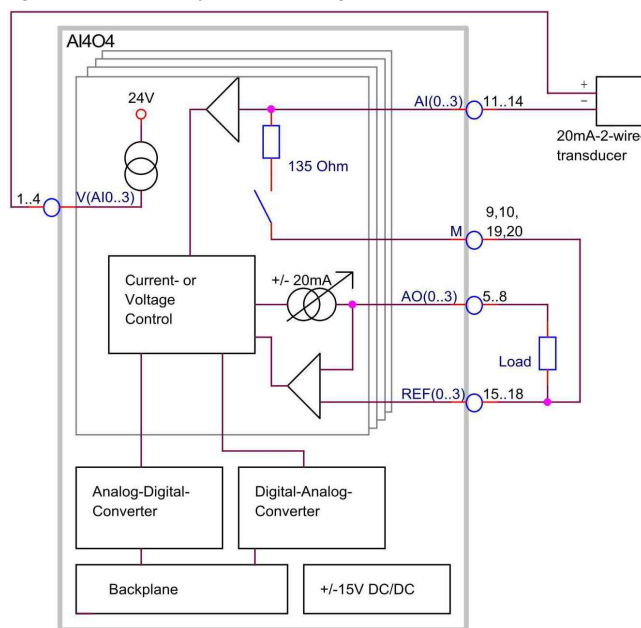

Figure above: Block diagram of PM AI4O4 with 2-wire encoders

Input		
Start address:	128	
End address:	135	
Channel	Address	Mode
Channel 1:	128	+/- 10V
Channel 2:	130	+/- 10V
Channel 3:	132	+/- 5V
Channel 4:	134	+/- 2.5V
		4...20mA
		0...20mA
Output		
Start address:	128	
End address:	135	
Channel	Address	Mode
Channel 1:	128	+/- 10V
Channel 2:	130	4...20mA
Channel 3:	132	+/- 20mA
Channel 4:	134	+/- 10V

Figure above: configuration block of start-/end addresses of AI4O4-i/o's (in words) in the ConfigStage

Periphery module AI4O4 (4 analog in- and 4 analog outputs)

Description

compact periphery module for

- 4 analog inputs to be configured by software
0...20mA, 4...20mA, 0...10 V, ±10V, ±5V, ±2,5V

4 analog outputs to be configured by software
± 20mA, 4...20mA, ±10V

- Resolution 12 Bit
- green diagnostic LED for each input
 - LED 1 for AI0
 - LED 2 for AI1
 - LED 3 for AI2
 - LED 4 for AI3
- red diagnostic LED for each input for error (sensor-/ broken wire detection)
 - LED 1 for AI0
 - LED 2 for AI1
 - LED 3 for AI2
 - LED 4 for AI3
 (or output error flag)
 - LED 5 for AO0
 - LED 6 for AO1
 - LED 7 for AO2
 - LED 8 for AO3
- Increase of the resolution of analog inputs by expanding the integration time up to 16 Bit
- insertion stripe with description field for every signal

Attention!

This module has an internal supply for the 2-wire encoders (4-20mA).

Do not connect pins 1-4 when using 3/4-wire encoders!

Always connect Ref0..3 with analog ground (0V)

for 3-/ 4-wire encoders or ±10V voltage source

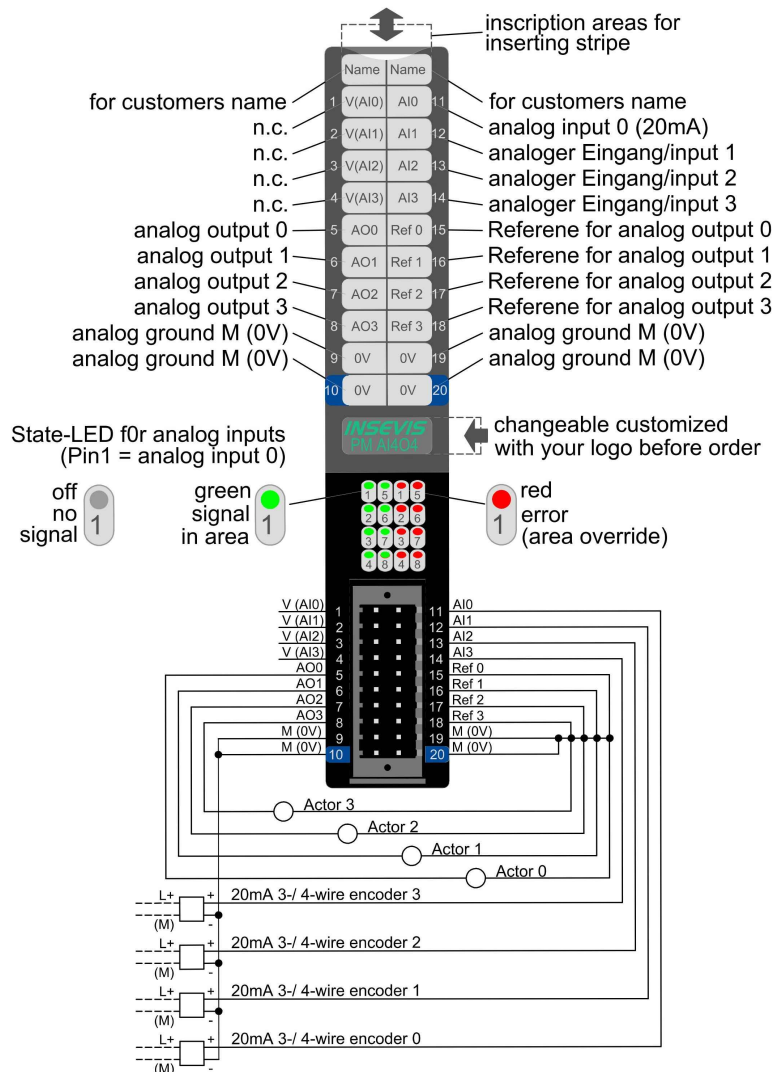

Figure above: Description and wiring of all connections of PM AI4O4 with 3-/ 4-wire encoders or ±10V

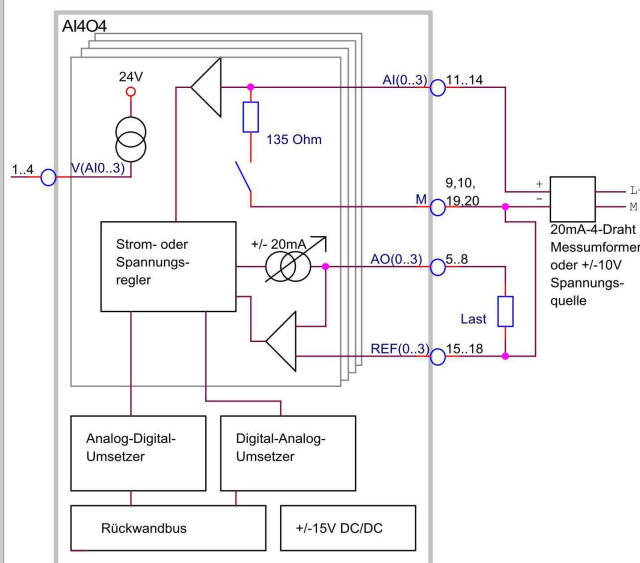

Figure above: Block diagram of PM AI4O4 with wire encoders or ±10V voltage source

Input		
Start address:	128	
End address:	135	
Channel	Address	Mode
Channel 1:	128	+/- 10V
Channel 2:	130	+/- 5V
Channel 3:	132	+/- 2.5V
Channel 4:	134	4...20mA
		0...20mA
Output		
Start address:	128	
End address:	135	
Channel	Address	Mode
Channel 1:	128	+/- 10V
Channel 2:	130	4...20mA
Channel 3:	132	+/- 20mA
Channel 4:	134	+/- 10V

Figure above: configuration block of 3-/ 4-start-/ end addresses of AI4O4-i/o's (in words) in the ConfigStage

Periphery module AI4O4 (4 analog in- and 4 analog outputs)

Technical data			
Operating temperature range Storage temperature range Dimensions W x H x D (mm) Weight	-20°C ... +60°C (without condens.) -30°C ... +80°C 20 x 108 x 70 mm ca. 150 g	Load voltage L+ Current consumption Power dissipation	24V DC (10V ... 30V DC, connected by device supply) 250 mA (max.) 4 W (max.)
Connection technology	cage clamp connector with lift-arms or bolt flanges on the sides (cage clamp technology) for cross section up to max. 1,5mm ²	Wire length unshielded (max.) shielded (max.)	30 m 100 m
Analog inputs Input area (nominal values)	4 (to be configured by software) 0...20mA, 4...20mA ±10V, ±5V, ±2,5V, 0..10V	Valid voltage between inputs and A-GND (max.)	-15 V ... +24 V DC
Diagnostic LEDs	4 green: signal in valid area 4 red: override (mA) or saturation no displaying broken wires and open inputs	Error message during override metering area	adjustable diagnosis- and limit value alert on request
Value number format	0000 ... 6C00 (hexadecimal) for range mA and 0 ... 10V all other 9400 ... 6C00 (hexadecimal)	Broken wire detection	by overrun / shortfall of metering area
Override area	20 mA ... 22 mA (only at mAs)	Access of sensor	unsymmetric against A-GND (single ended)
Input resistance	150Ω (typ.) metering area current 100kΩ (typ.) metering area voltage	Metering principle / conversion principle Resolution depending on integration time *	successive approximation 12 Bit ... 16 Bit
Sampling cycle time = Integration time *	adjustable 1ms ... 35767 ms default: 100 ms (=Net frequency filter 50Hz and 60Hz)	Specifyity (based on input area)	< 1%
Analog outputs Output area (nominal values)	4 (to be configured by software) ±20mA, 4...20mA, ±10V	Value number format	0000 ... 6C00 (hexadecimal) for range mA and 0 ... 10V all other 9400 ... 6C00 (hexadecimal)
Resolution	12 Bit	Short cut protection	ja
Diagnostic LEDs	4 green: signal in valid area 4 rot: override (mA) or short circuit	Override area	20 ... 23 mA, -20 ... -23 mA 10 ... 11,3V, -10 ... -11,3V
Resolution	12 Bit	Short cut current (typ.)	32 mA
Load resistance against A-GND	mA: 500 Ω (max.) V: 1 kΩ (min.)	Specifyity (based on output area)	< 1%

* Increment of the resolution of analog inputs by expanding the integration time (configurable in ConfigStage at the PM-AI4O4 directly)

for 0..10V:	0...16ms → 13Bit	17...64ms → 14Bit	65...256ms → 15Bit	
for 0(4)..20mA:	0...16ms → 12Bit	17...64ms → 13Bit	65...256ms → 14Bit	> 265ms → 15Bit
for ±2,5V, ±5V, ±10V:	0...16ms → 12Bit (+sign)	17...64ms → 13Bit (+sign)	65...256ms → 14Bit (+sign)	> 265ms → 15Bit (+sign)

Configuration of the process image

The module allocates 8 input words and 4 output words in the process image. (Hardware version 2.0)			
Offset	I/O	Function	Description
0,2,4,6	I	Input AI0..AI3	Measuring range according to configuration
0,2,4,6	O	Output AO0..AO3	Measuring range according to configuration
8,10,12,14	I	State of the (backreadable) outputs AO0..AO3	.0 FCM Common-Mode Over-Range .1 FLD Load Error .2 FOT Over Temperature .153 0 ... 6C00 (hex) at mA: output voltage 0 ... 10V ati ±10V: output current 0 ... 20mA

Periphery module AI8O2 (8 analog in- and 2 analog outputs)

Description

compact periphery module for

- 8 analog inputs
 4x 4...20mA
 4x PT100 -80°C ... 300°C

2 analog outputs
 2x 4...20mA)

- Resolution 12 Bit
- green diagnostic LED for each input
- red diagnostic LED for each input for error (sensor-/ broken wire detection or temperature below - 50°C)
- insertion stripe with description field for every signal

INSEVIS-benefit:

This module has an internal supply for the 2-wire encoders (4-20mA). So it is not necessary to care for external supply!

If you use these pins 1-4, do not apply external encoder supply!

for 2-wire encoders

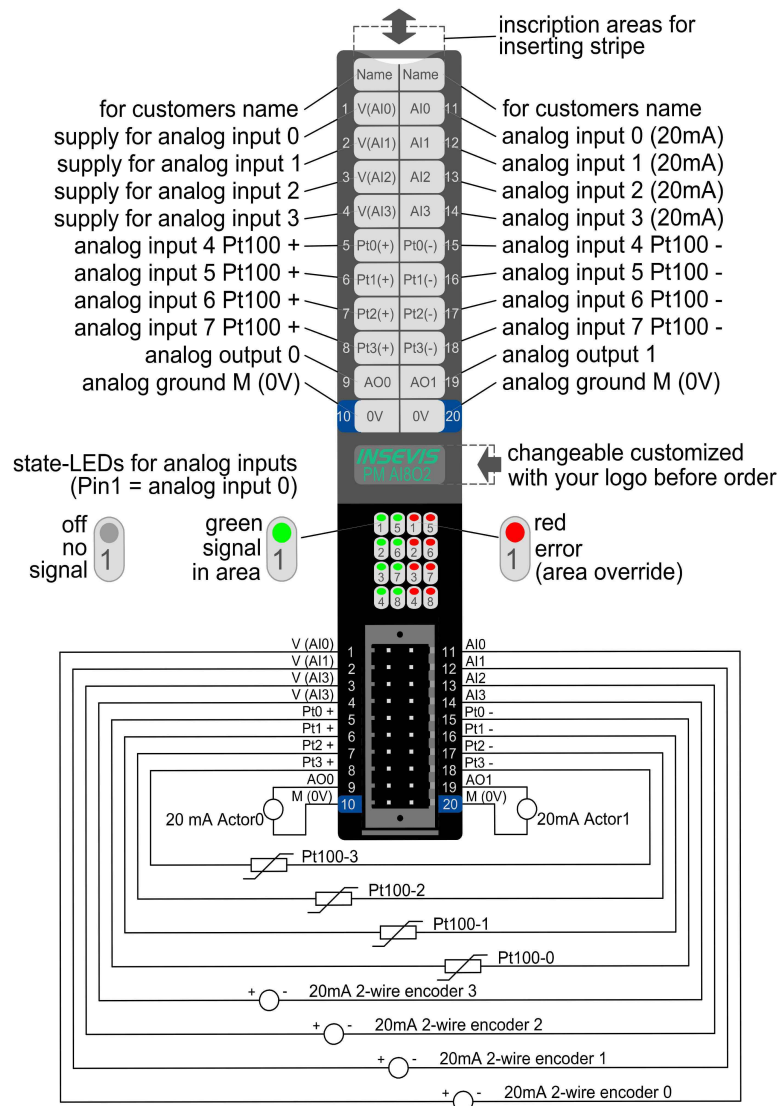

Figure above: Description and wiring of all connections of periphery module AI8O2 for 2-wire encoders

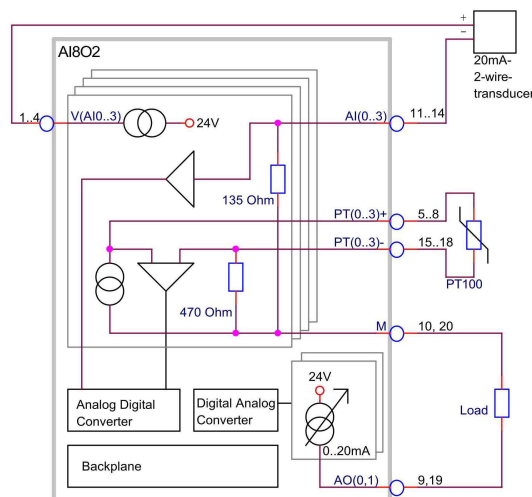

Figure above: Block diagram PM AI8O2 for 2-wire encoders

Input	
Start address:	128
End address:	143
Output	
Start address:	128
End address:	131
General	
Integration time [ms]	0

Figure above: configuration block of the start-/ end addresses of AI8O2-i/o's (in words) in the ConfigStage

Periphery module AI8O2 (8 analog in- and 2 analog outputs)

Description

compact periphery module for

- 8 analog inputs
4x 4...20mA
4x PT100 -80°C ... 300°C

2 analog outputs
2x 4...20mA

- Resolution 12 Bit
- green diagnostic LED for each input
- red diagnostic LED for each input for error (sensor-/ broken wire detection or temperature below - 50°C)
- insertion stripe with description field for every signal

Attention!

This module has an internal supply for the 2-wire encoders (4-20mA).

Do not connect pins 1-4 when using 3/4-wire encoders!

for 3- / 4-wire encoders

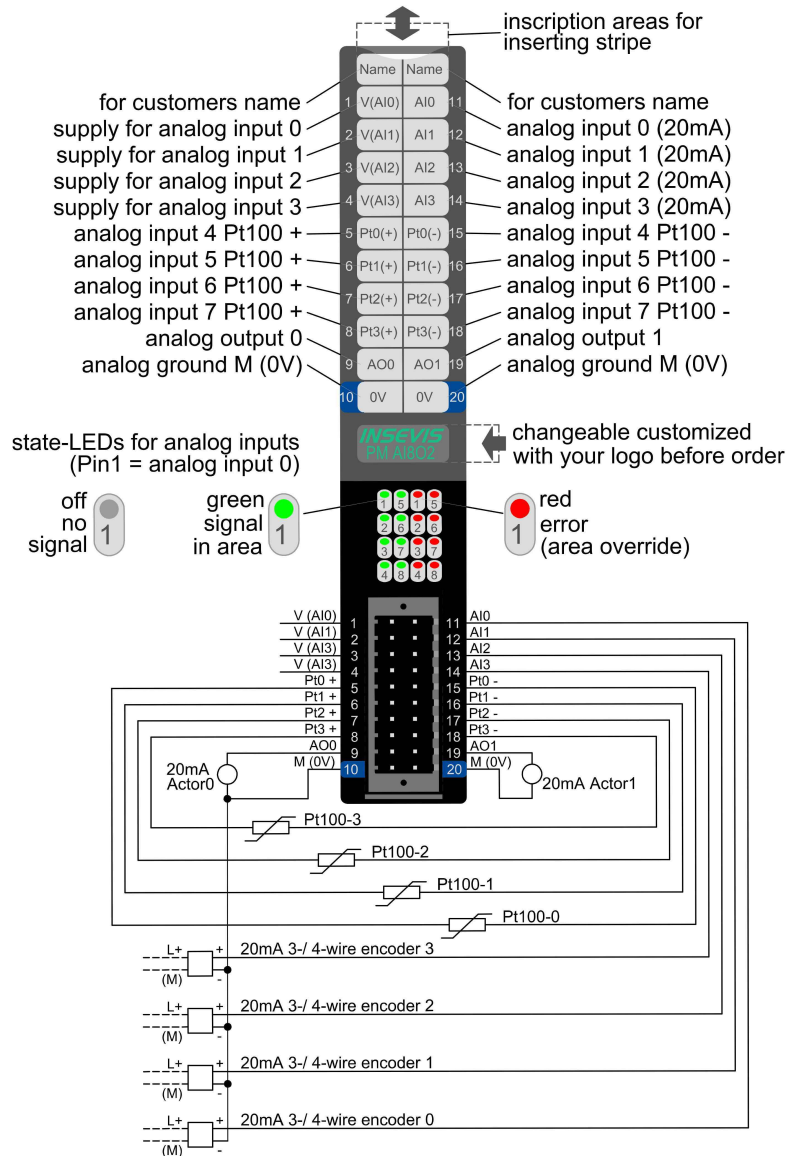

Figure above: Description and wiring of all connections of periphery module AI8O2 for 3-/ 4-wire encoders

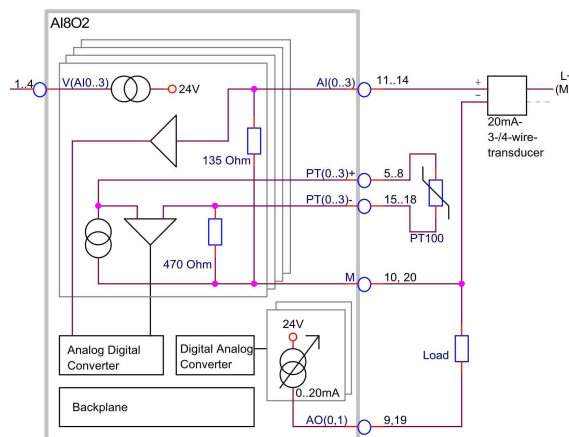

Figure above: Block diagram PM AI8O2 for 3-/ 4-wire encoders

Input	
Start address:	128
End address:	143
Output	
Start address:	128
End address:	131
General	
Integration time [ms]	0

Figure above: configuration block of the start-/ end addresses of AI8O2-i/o's (in words) in the ConfigStage

Periphery module AI8O2 (8 analog in- and 2 analog outputs)

Technical data			
Operating temperature range Storage temperature range Dimensions W x H x D (mm) Weight	-20°C ... +60°C (without condens.) -30°C ... +80°C 20 x 108 x 70 mm ca. 150 g	Load voltage L+ Current consumption Power dissipation	24V DC (10V ... 30V DC, connected by device supply) 150 mA (max.) 2 W (max.)
Connection technology	cage clamp connector with lift-arms or bolt flanges on the sides (cage clamp technology) for cross section up to max. 1,5mm ²	Wire length unshielded (max.) shielded (max.)	30 m 100 m
Analog inputs	8	valid voltage between inputs and A-GND (max.)	0 V ... +24 V DC
Input area (nominal values)	AE 0...3: 4 mA ... 20 mA AE 4...7: PT100 -200°C ... +300°C	Error message during override metering area	adjustable diagnosis- and limit value alert on request
Under- / override areas	0 mA ... < 4mA >20 mA ... 23 mA -243°C ... <-200°C >+300°C ... +450°C	Broken wire detection	by overrun / shortfall of metering area
Diagnostic LEDs	4 green: 4-10mA-signal in valid area 4 green: PT100: -50°C ... 300°C 4 red: override (mA) or short circuit 4 red: PT100-short cut or temperature below ≤ - 50°C no displaying broken wires and open inputs	Access of sensor	unsymmetric against A-GND (single ended) for metering area 4 mA ... 20 mA 2-wire, symmetric for metering area PT100
Input resistance	120 Ω (typ.) metering area 20 mA 500 Ω (typ.) metering area PT100	Value number format	0000 ... 6C00 (hexadecimal) for metering area 4 mA ... 20 mA 0,1°C for metering area PT100
Resolution	12 Bit	Integration time	adjustable 17 ms or 20 ms
Metering principle / conversion principle	successive approximation	Specify (based on input area)	< 1%
Sampling cycle time (typ)	1 ms	Current limitation	50 mA
Analog outputs	2	Value number format	0000 ... 6C00 (hexadecimal) for metering area 4 mA ... 20 mA
Output area (nominal values)	4 mA ... 20 mA	Short cut protection	yes
Override area	20 mA ... 23 mA	Short cut current (typ.)	32 mA
Resolution	12 Bit	Setting time:	response time τ (typ) 5 ms
Load resistance against A-GND	4..20 mA: 500 Ω (max.)	Specify (based on output area)	< 1%

Periphery module RTD8O2 (8 RTD-inputs and 2 analog outputs)

Description

compact periphery module for

- 8 analog inputs to be configured by software

Temperature:
 PT100,
 PT1000,
 NI100,
 NI1000,
 KTY81-1xx
 Resistivity survey
 200Ω ,
 2kΩ
 Voltage:
 0 .. 400mV,
 0 .. 1V

2 analog outputs
 (0,5 ...10V)

• Resolution 12 Bit

• green diagnostic LED for each input

- LED 1 for AI0
- LED 2 for AI1
- LED 3 for AI2
- ...
- LED 8 for AI7

• red diagnostic LED for each input for error (sensor-/ broken wire detection)

- LED 1 for AI0
- LED 2 for AI1
- LED 3 for AI2
- ...
- LED 8 for AI7

• insertion stripe with description field for every signal

for 2-wire RTDs

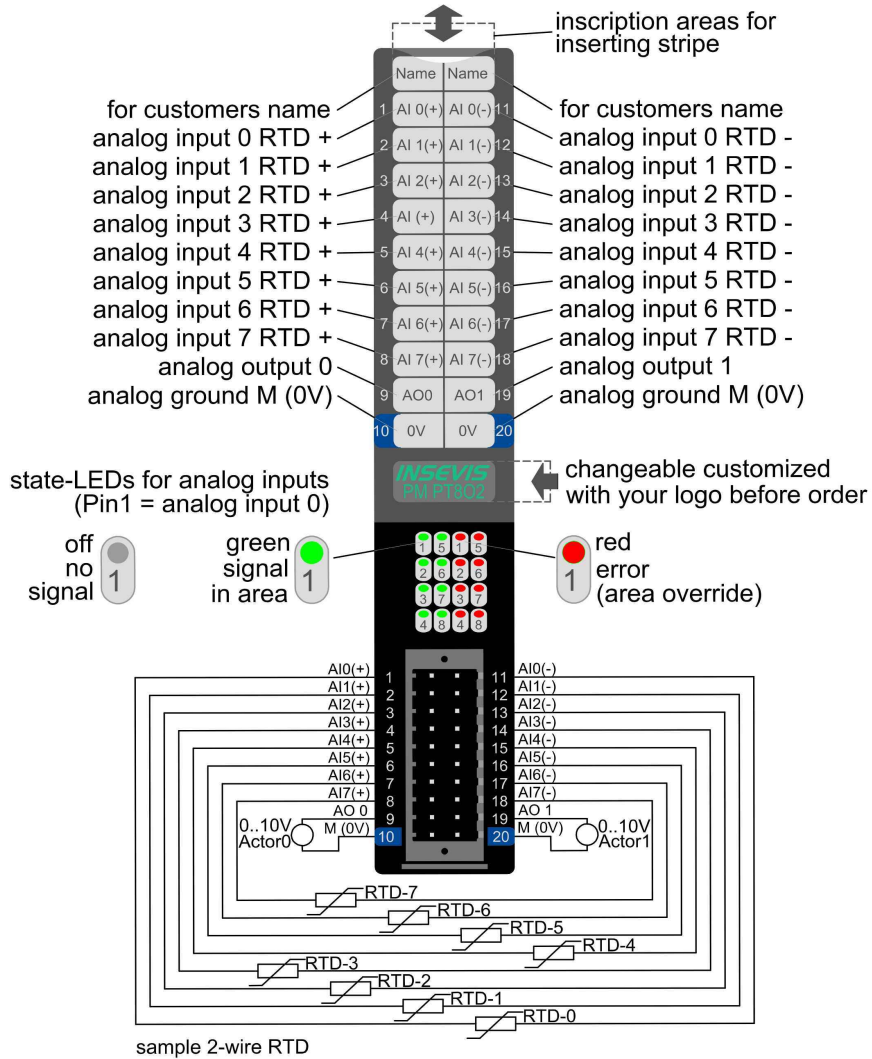
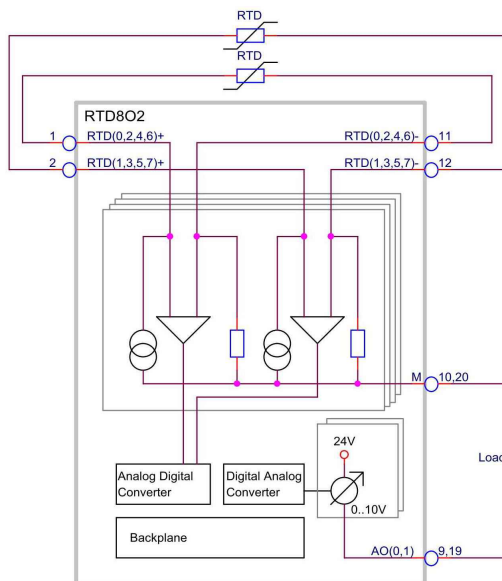

Figure above: Description and wiring of all connections of periphery module RT8O2 with 2-wire RTDs



above: block diagram of RTD8O2 for 2-wire RTDs

Input		
Start address:	128	
End address:	143	
Channel	Address	Type
Channel 1:	128	PT100 (2-wire)
Channel 2:	130	PT100 (3-wire)
Channel 3:	132	PT100 (4-wire)
Channel 4:	134	PT1000 (2-wire)
Channel 5:	136	PT1000 (3-wire)
Channel 6:	138	PT100 (2-wire)
Channel 7:	140	PT100 (2-wire)
Channel 8:	142	PT100 (2-wire)
Output		
Start address:	128	
End address:	131	

above: configuration block of start-/ end addresses of RTD8O2-i/o's (in words) in the ConfigStage

Periphery module RTD8O2 (8 RTD-inputs- and 2 analog outputs)

Description

compact periphery module for

- 8 analog inputs to be configured by software

Temperature:
 PT100,
 PT1000,
 NI100,
 NI1000,
 KTY81-1xx
 Resistivity survey
 200Ω ,
 2kΩ
 Voltage:
 0 .. 400mV,
 0 .. 1V

2 analog outputs
 (0,5 ...10V)

- Resolution 12 Bit
- green diagnostic LED for each input
 - LED 1 for AI0
 - LED 2 for AI1
 - LED 3 for AI2
 - ...
 - LED 8 for AI7
- red diagnostic LED for each input for error (sensor-/ broken wire detection)
 - LED 1 for AI0
 - LED 2 for AI1
 - LED 3 for AI2
 - ...
 - LED 8 for AI7
- insertion stripe with description field for every signal

for 3-wire RTDs

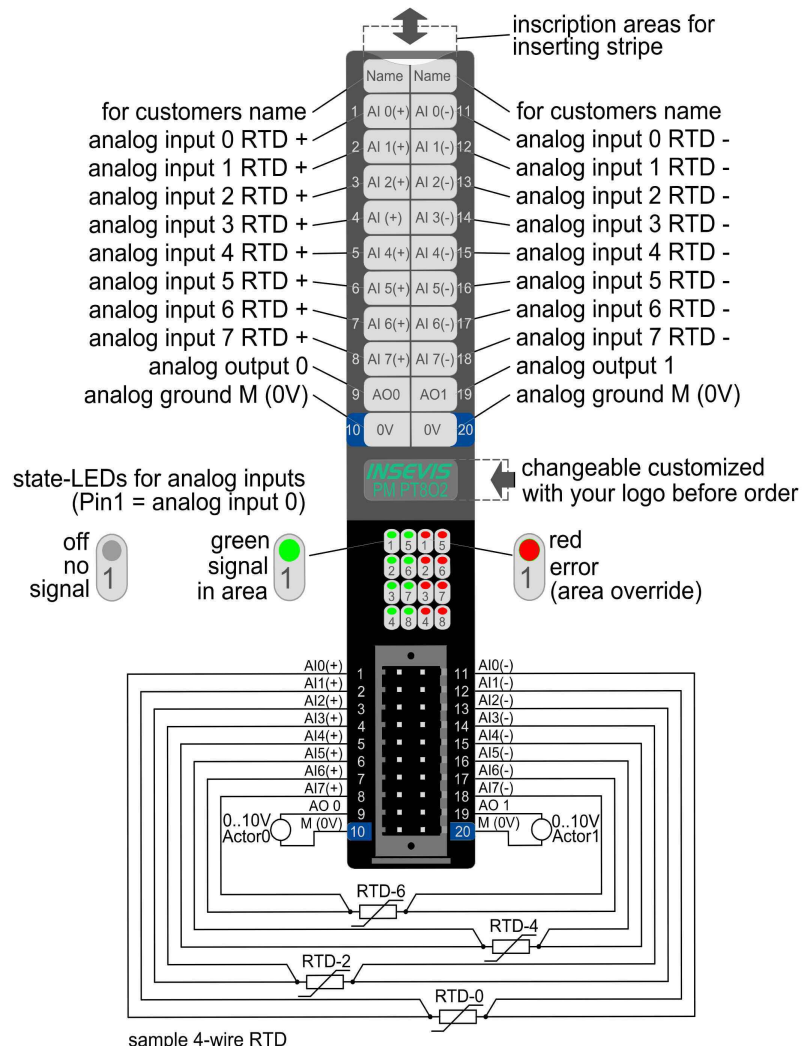
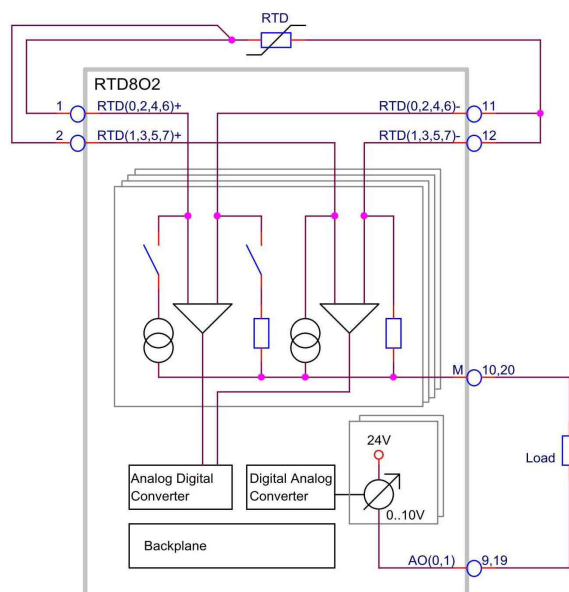
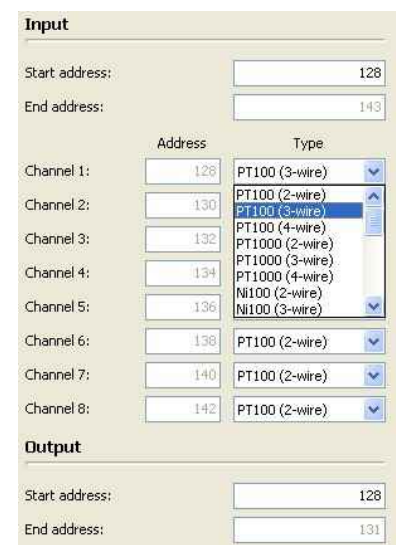

Figure above: Description and wiring of all connections of periphery module RT8O2 with 3-wire RTDs



above: block diagram of RTD8O2 for 3-wire RTDs



above: configuration block of start-/ end addresses of RTD8O2-i/o's (in words) in the ConfigStage

Periphery module RTD802 (8 RTD-inputs- and 2 analog outputs)

Description

compact periphery module for

- 8 analog inputs to be configured by software

Temperature:
 PT100,
 PT1000,
 NI100,
 NI1000,
 KTY81-1xx
 Resistivity survey
 200Ω ,
 2kΩ
 Voltage:
 0 .. 400mV,
 0 .. 1V

2 analog outputs
 (0,5 ...10V)

- Resolution 12 Bit

- green diagnostic LED for each input
 - LED 1 for AI0
 - LED 2 for AI1
 - LED 3 for AI2
 - ...
 - LED 8 for AI7

- red diagnostic LED for each input for error (sensor-/ broken wire detection)
 - LED 1 for AI0
 - LED 2 for AI1
 - LED 3 for AI2
 - ...
 - LED 8 for AI7

- insertion stripe with description field for every signal

for 4-wire RTDs

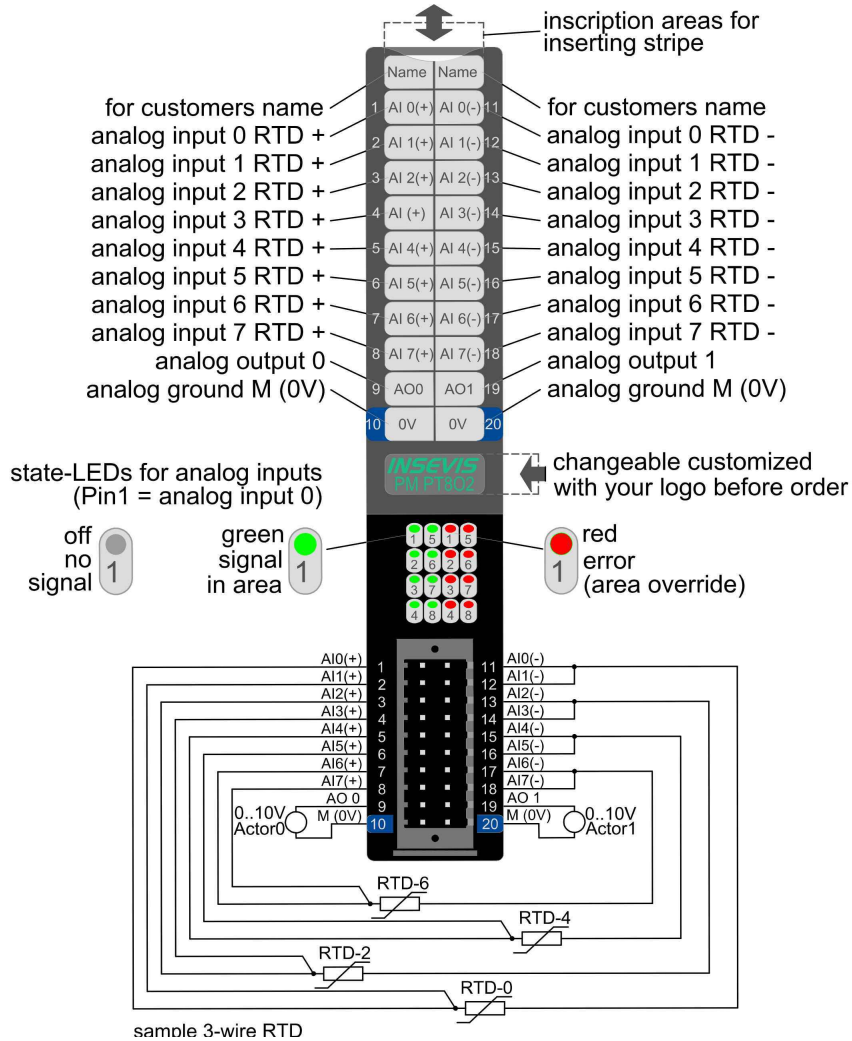
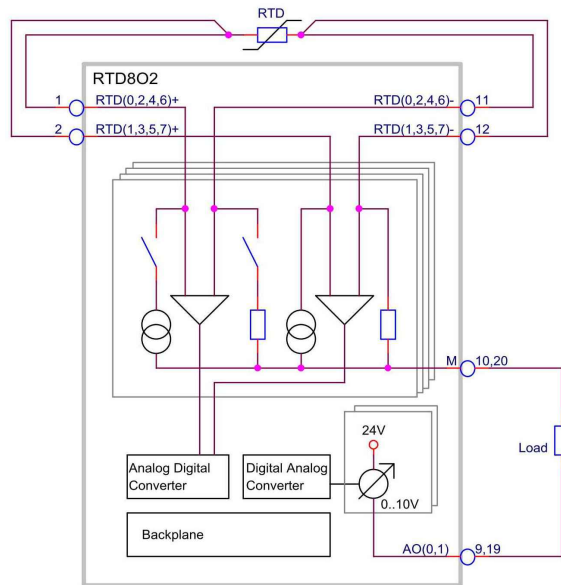

Figure above: Description and wiring of all connections of periphery module RT802 with 4-wire RTDs



above: block diagram of RTD802 for 4-wire RTDs

Input		
Start address:	128	
End address:	143	
Channel	Address	Type
Channel 1:	128	PT100 (4-wire)
Channel 2:	130	PT100 (2-wire)
Channel 3:	132	PT100 (3-wire)
Channel 4:	134	PT100 (4-wire)
Channel 5:	136	PT100 (2-wire)
Channel 6:	138	PT100 (2-wire)
Channel 7:	140	PT100 (2-wire)
Channel 8:	142	PT100 (2-wire)
Output		
Start address:	128	
End address:	131	

above: configuration block of start-/ end addresses of RTD802-i/o's (in words) in the ConfigStage

Periphery module RTD8O2 (8 RTD-inputs- and 2 analog outputs)

Description

compact periphery module for

- 8 analog inputs to be configured by software

Temperature:

- PT100,
- PT1000,
- NI100,
- NI1000,
- KTY81-1xx

Resistivity survey

200Ω ,

2kΩ

Voltage:

0 .. 400mV,

0 .. 1V

2 analog outputs (0,5 ...10V)

- Resolution 12 Bit

• green diagnostic LED for each input

- LED 1 for AI0
- LED 2 for AI1
- LED 3 for AI2
- ...
- LED 8 for AI7

• red diagnostic LED for each input for error (sensor-/ broken wire detection)

- LED 1 for AI0
- LED 2 for AI1
- LED 3 for AI2
- ...
- LED 8 for AI7

• insertion stripe with description field for every signal

for voltage measurement

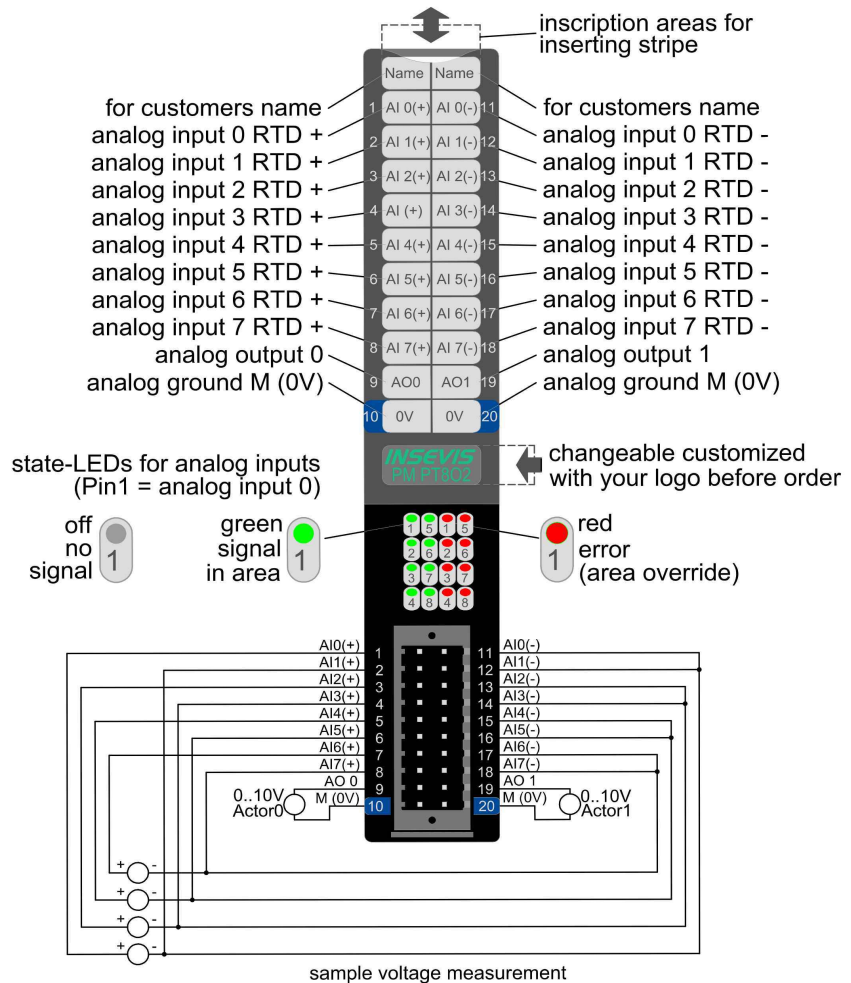
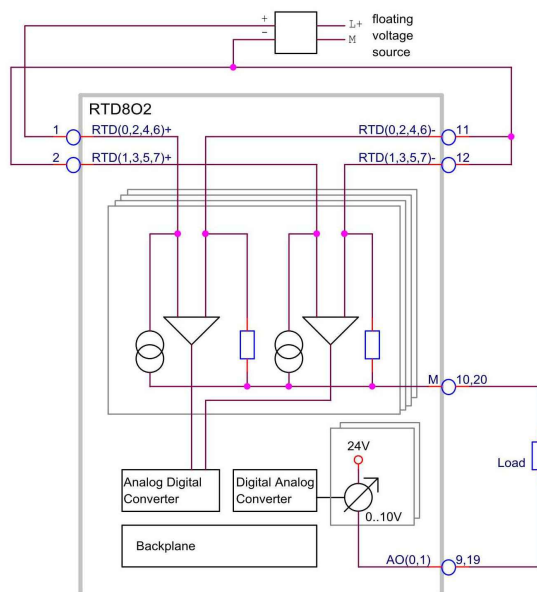

Figure above: Description and wiring of all connections of PM RT8O2 for voltage measurement



above: block diagram of RTD8O2 for voltage measurement

Input		
Start address:	128	
End address:	143	
Channel	Address	Type
Channel 1:	128	PT100 (4-wire)
Channel 2:	130	0..300 Ohm (3-wire)
Channel 3:	132	0..300 Ohm (4-wire)
Channel 4:	134	0..2k Ohm (2-wire)
Channel 5:	136	0..2k Ohm (3-wire)
Channel 6:	138	0..2k Ohm (4-wire)
Channel 7:	140	0..400mV
Channel 8:	142	0..1V
		Not available
Output		
Start address:	128	
End address:	131	

above: configuration block of start-/ end addresses of RTD8O2-i/o's (in words) in the ConfigStage

Periphery module RTD8O2 (8 RTD-inputs- and 2 analog outputs)

Technical data			
Operating temperature range Storage temperature range Dimensions W x H x D (mm) Weight	-20°C ... +60°C (without condens.) -30°C ... +80°C 20 x 108 x 70 mm ca. 150 g	Load voltage L+ Current consumption Power dissipation	24V DC (10V ... 30V DC, connected by device supply) 50 mA (max.) 1,2 W (max.)
Connection technology	unlockable connector with 2 lift-arms or bolt langes on side (cage clamp technology) for cross section up to max. 1,5mm ²	Wire length unshielded (max.) shielded (max.)	30 m 100 m
Analog inputs	8	valid voltage between inputs and A-GND (max.)	0 V ... +24 V DC
Diagnostic LEDs	8 green: signal in valid area 8 rot: short circuit no displaying broken wires and open inputs	Error message during override metering area	adjustable diagnosis- and limit value alert on request
Input area (nominal values)	PT100: -50°C ... 600°C PT1000: -50°C ... 250°C Ni100: -50°C ... 250°C Ni1000: -50°C ... 150°C KTY81/1xx: -50°C ... 150°C 0 ... 300 Ω, 0 ... 2 kΩ	Override area (LEDs off)	PT100: >600°C ... 620°C PT1000: >250°C ... 300°C Ni100: >250°C ... 275°C Ni1000: >150°C ... 175°C KTY81/1xx: >125°C ... 150°C >300 Ω ... 325 Ω, >2 kΩ ... 2,1 kΩ
Value number format	0,1°C for temperature metering area, 0,1° Ω for resistor metering area, 0000 ... 6C00 (hexadecimal) for voltage metering area	Underride area (red LED on)	PT100: -200°C ... < -50°C PT1000: -200°C ... < -50°C Ni100: -200°C ... < -50°C Ni1000: -200°C ... < -50°C KTY81/1xx: -75°C ... < -50°C
Input resistance	500 Ω (typ.) metering area PT100	Access of sensor	2- or 4- wire, symmetric
Resolution	12 Bit		
Metering principle / conversion principle	successive approximation	Broken wire detection	by overrun, shortfall of metering area (only at 2 wire use!)
Sampling cycle time = Integration time	adjustable 1ms ... 35767 ms default: 100 ms (=Net frequency filter 50Hz + 60Hz)	Specifity (based on input area)	< 1%
Analog outputs	2	Value number format	0000 ... 6C00 (hexadecimal)
Output area (nominal values)	0,5 ... 10V	Short cut protection	yes
Override area	0 ... 11V	Short cut current (typ.)	32 mA
Resolution	12 Bit	Setting time:	response time τ (typ) 1,5 ms
Load resistance against A-GND	1kΩ (max.)	Specifity (based on output area)	< 1%

Function module DIO8-Z (8 digital in/ -outputs / encoder inputs)

Description

compact periphery module with 6 dedicated input channels and 2 fast back-readable outputs 24V/2A in 3 hardware versions:

for 24V:
6 digital inputs 24V
2 digital back-readable outputs 24V/2A
(Art.-Nr. PM-DIO8Z-24V-03)

for 5V
6 digital back-readable outputs 5V
2 digital back-readable outputs 24V/2A
(Art.-Nr. PM-DIO8Z-5V-03)

for RS422
6 bidirectional channels according RS485 / RS422
2 digital back-readable outputs 24V/2A
(Art.-Nr. PM-DIO8Z-422-03)

configurable by software to:
 - 2 up/down-counter for encoder or puls and direction signal reference track
 2 compare-outputs

or
 - 2 counter to measure frequency or time period for encoder or puls and direction signal
 2 compare-outputs

- alert function
- Counting with 32 Bit
- time resolution 40 ns
- configurable input filter
- green diagnostic LED for each in-/ output
- insertion stripe with description field for every signal
- insertion stripe with description field for every signal

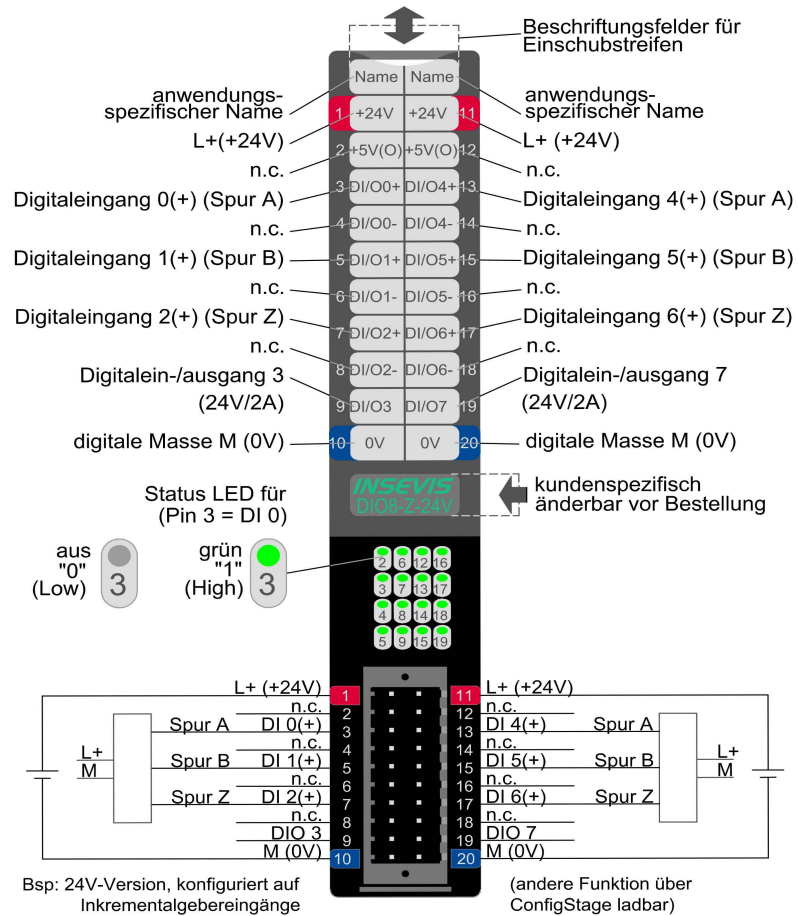

Figure above: description and wiring of all connections of periphery module DIO8Z-24V-03

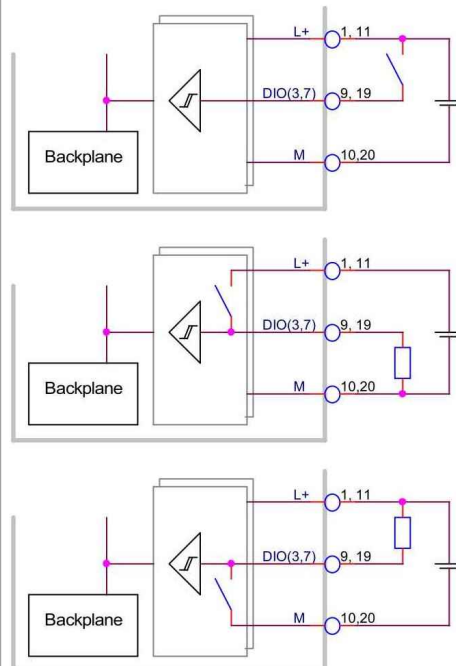

Figure above: block diagram of DIO3 and DIO7 as input (top), as output (L+ switching, middle) and as output (M-switching, down)

The screenshot shows the 'Input' and 'Output' address ranges (0-11) and the 'Counter' configuration set to 'Up and Down-Counter'. A 'DIO8Z Counter configuration' dialog box is open, showing:

- Description: Up and Down-Counter
- Version: v1.0
- Counter input: Disabled
- Input filter: 1 µs
- Compare value: 0

Figure above: configuration in ConfigStage

Function module DIO8-Z (8 digital in/ -outputs / encoder inputs)

Technical data	
Dimensions W x H x D (mm)	20 x 108 x 70 mm
Weight	ca. 150 g
Operating temperature range	-20°C ... +60°C (without condensation)
Storage temperature range	-30°C ... +80°C
Connection technology	cage clamp connector with lift-arms or bolt flanges on the sides (cage clamp technology) for cross section up to max. 1,5mm ²
Load voltage L+	10 V ... 30 V DC
Current consumption	20 mA (max.) without load
Power dissipation	internal limited
Wire length unshielded (max.)	30m
shielded (max.)	100m

DI/O0 ... DI/O2, DI/O4 ... DI/O6	24V	5V (RS422 without terminating resistor)	RS422 (with terminating resistor)
Digital inputs	8 (max.), all with alert-function (interrupt)		
Diagnostic LEDs	8, green		
Article number	PM-DIO8Z-24V-03	PM-DIO8Z-5V-03	PM-DIO8Z-422-03
Input voltage for signal 0	0V ... +5V	0 .. +3V	
for signal 1	+7,5V ... +30V	+4 .. +5V	
positive switching	DI/O0(+) .. 7(+): signal DI/O0(-)..2(-), 4(-) .. 6(-): open	DI/O0(+) ..2(+), 4(+) .. 6(+): signal DI/O0(-)..2(-), 4(-) .. 6(-): open	
Input voltage for signal 0	+2V ... +30V	+2..+5V	
for signal 1	0V ... +1V	0..+1V	
negative switching "open collector"	DI/O0(+) .. 2(+), 4(+) .. 6(+): open DI/O0(-) .. 2(-), 4(-) .. 6(-): signal	DI/O0(+) .. 2(+), 4(+) .. 6(+): open DI/O0(-) .. 2(-), 4(-) .. 6(-): signal	
Inputs (differential)	-	differential reg. RS422	
Outputs	-	differential reg. RS422	
Input resistance	-	1,5 kOhm	150 Ohm
Input current for signal 1	max. 1mA (subject to change)		
Broken wire detection	no		
Error diagnostic	no		
Potential separation to PLC	no		
Input delay	2 µs (typ.)		
Output delay	2 µs (typ.)		
Max. counting frequency	125kHz (subject to change)		

DI/O3, DI/O7			
Digital outputs	2 with L+		
Diagnostic LEDs	2, green		
Output signal level for signal 0	1,0 V bei 500Ω (max.)	Input signal level for signal 0	0V ... +5V
for signal 1	L+ - 1,0V bei 0,5A Last (min.)	for signal 1	+7,5V ... +30V
Output current for signal 0	0,5mA (max.)		
for signal 1	2 A (max. bis 60°C, subject to change)		
Output delay	30 µs (typ., without load)	Input delay	50 µs (typ.)
Max. switching frequency with ohmic load	100 Hz		
Broken wire detection	no		
Error diagnostic	no		
Potential separation to PLC	no		

Function module DIO8-Z (8 digital in/ -outputs / encoder inputs)

The function module DIO8Z is a counter module with 6 function channels and 2 fast digital back-readable outputs.

Signal level

Function channels are available in 24V-, 5V- and RS422-versions (to be configured at INSEVIS only). Bi-directional functions are possible only in 5V- and RS422-versions.

Configuration “up/down counter”

(hardware version 4.0, configuration vers. 1.000)

The function module contains 2 fast forward- and backward counters with alternative interfaces for encoder or pulse and direction signals.

The counter register has a preset- and a reference function.

The encoder interface always quadruples (x4) the number of physical pulses.

Preset and Reset

Counter can be preset in an asynchronous way with any values by the preset function. The new setpoint is written into the setpoint register (for reset write “0”) and activated by a bit inside of the control byte.

Homing

The reference (homing-) function sets back the counter in a synchronous way onto an external reference signal (Z-trace).

The homing mode will be started by setting a bit inside of the control byte and keeps active until the reference signal is detected.

Then the counter returns into normal operation mode. The appearance of the reference signal can be requested by status bits.

Compare

The compare output will become active when the counter value exceeds the configured Compare value. To configure the compare value the new value is written into the setpoint register and activated by a bit inside of the control byte.

Output 0.3 resp. 0.7 and the counter compare output are logical xor-ed. Setting the output value bit inverts the compare- output (and vice versa)

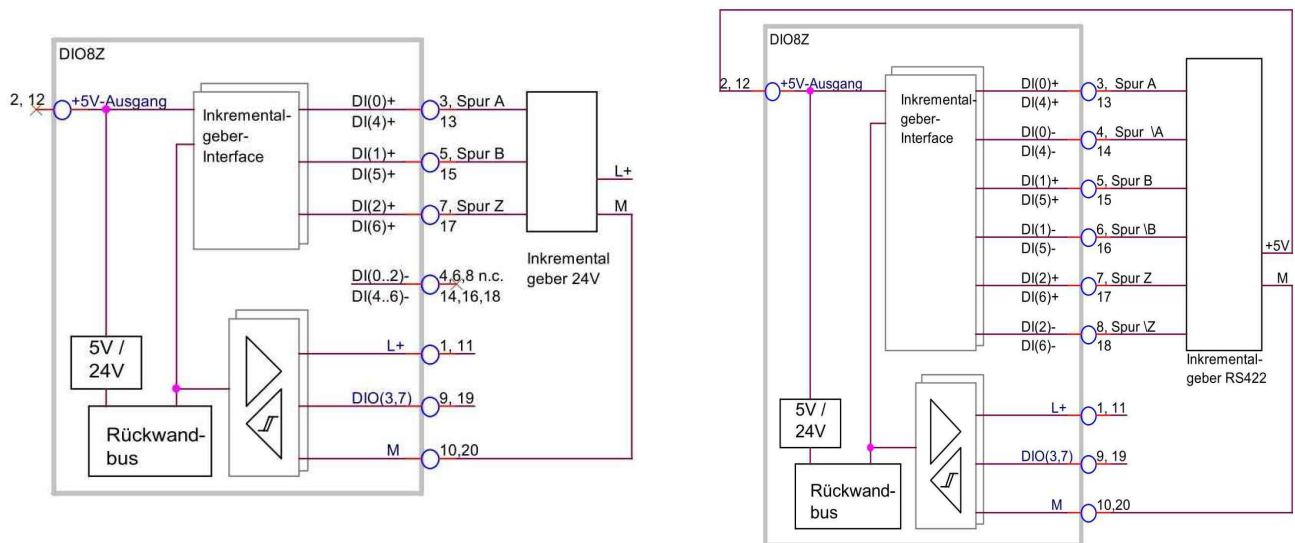

Samples: Block diagrams of DIO8-Z(24V) with 24V-encoders and DIO8-Z(RS422) with RS422-encoders

S7-Data

The 32 bit counters are latched with the read of the less significant byte (LSB) into a mirror register. The remaining bytes are read from there. So it is possible to use byte, word and dword access. Consider to always read the LSB first to get a new and consistent counter value. Due to S7's high endian addressing the physical LSB is read at offset 3 using byte and at offset 2 using word access.

The control byte works static, i.e. the control bits must be set and reset. Consider that the process image will be updated at control point time – wait 1 cycle between set and reset or use direct periphery access.

Setup

The setup für input-mode (inaktiv/aktiv, encoder or pulse/direction), filter time and compare value can be done in the software “ConfigStage”. It is also possible to change these value at runtime from S7-code.

Function module DIO8-Z (8 digital in/ -outputs / encoder inputs)

Hardware Interrupt (for “-T”-series devices only)

The compare output of each counter is assigned to an alarm channel. Each channel is to be enabled or disabled at runtime by a control bit (offset 11) separately.

In case of enabled channel and active compare output OB40 will be called. While the runtime of OB40 new events of the same channel are ignored.

Parameter OB40_MDL_ADDR of OB40's local data contains the base address of the peripheral modul, parameter OB40_POINT_ADDR of OB40's local data contains status bits, corresponding the causing channel.

The format of the status bits is identical to the enable bits (.0 counter0, .1 counter1)

Assignment of process image “up/down counter”

The function module uses 12 byte in- and outputs in the process image.

Offset	I/O	Function	Description
0..3	I	Counter 0	32 bit forward and backward counter
	O	Setpoint register counter 0 (Config-, Compare-, Preset-Register)	asynchronous setpoint counter0, operation control bit depended
4..7	I	Counter 1	32 bit forward and backward counter
	O	Setpoint register counter 2 (Config-, Compare-, Preset-Register)	asynchronous setpoint of counter1 operation control bit depended
8	I	Input bits (status bits)	.0 pulse / trace A counter 0 .1 direction / trace B counter 0 .2 trace Z counter 0 .3 input 24V or status output 0.3 .4 pulse / trace A counter 1 .5 direction / trace B counter 1 .6 trace Z counter 1 .7 input 24V or status output 0.7
	O	Output enable bits	.0 - .7 output enable activate output driver of corresponding channel - not allowed when use channel as input - doesn't work at 0.-.2 and .4-.7 in 24V version
9	I	reserved	
	O	Output data bits	.0 - .7 output
10	I	Status byte	.4 reference mode counter 0 .5 reference mode counter 1 '1' reference mode active '0' reference impulse detected and counter resetted Mode 'counting'
	O	Control byte	.0 set preset counter 0 While this bit is 1 the output value from offset 0...3 will be carried over into counter 0. .1 set preset counter 1 While this bit is 1 the output value from offset 4...7 will be carried over into counter 1. .2 set compare value 0 While this bit is 1 the output value from offset 0...3 will be carried over into the compare register of counter 0. .3 set compare value 1 While this bit is 1 the output value from offset 4...7 will be carried over into the compare register of counter 1. .4 enable homing mode counter 1 .5 enable homing mode counter 2 If counter is in homing mode and trace Z is '1', the counter is resetted and the homing mode is left.

Function module DIO8-Z (8 digital in/ -outputs / encoder inputs)

Offset	I/O	Function	Description
	O	Control byte	.6 Set Config 0 .7 Set Config 1 While this bit is 1 the output value from offset 0...3 / 4...7 will be carried over into the configuration register .0 SW-Gate 0=STOP, 1=RUN .1 Mode_INK 0=Puls/Dir, 1=encoder 4x .2 res .3 res. .4 - 5 limit of input bandwidth 00 = 500kHz 01 = 30kHz 10 = 8kHz 11 = 2kHz .6 - .15 res. .16 - .31 res.
11	I	Status Alarm enable	State of enabled alarms
	O	Alarm enable	Alarm .0 enable compare counter 0 .1 enable compare counter 1

Description of function pins “up/down counter”

Pin	Identification	Function	Direction
1,11	+24V	common 24V-supply of outputs	Input / supply
2,12	5V(O)	common 5V-outputs to supply the encoders	Output
3	DI/O0+	positive switching input trace A / pulse counter0	Input
4	DI/O0-	negative switching input ¹⁾ trace /A counter0	Input
5	DI/O1+	positive switching input trace B / direction counter0	Input
6	DI/O1-	negative switching input ¹⁾ trace /B counter0	Input
7	DI/O2+	positive switching input trace Z counter0	Input
8	DI/O2-	negative switching input ¹⁾ trace /Z counter0	Input
9	DI/O3+	back-readable output ²⁾ 0.3	In / Out
10,2	0V	common reference potential	Input / supply
13	DI/O4+	positive switching input trace A counter1	Input
14	DI/O4-	negative switching input ¹⁾ trace /A counter1	Input
15	DI/O5+	positive switching input trace B counter1	Input
16	DI/O5-	negative switching input ¹⁾ trace \B counter1	Input
17	DI/O6+	positive switching input trace Z counter1	Input
18	DI/O6-	negative switching input ¹⁾ trace /Z counter1	Input
19	DI/O7+	back readable output ²⁾ 0.7	In / Out

¹⁾ keep pin unconnected at hardware version „24V“, optional use in version „5V“

²⁾ default configuration: input

Function module DIO8-Z (8 digital in/ -outputs / encoder inputs)

Description of the status-LEDs configuration “up/down counter”

Pin	Identification	Function
2,12	5V	5V-supply voltage ok
3	DI/O0	State on input .0 pulse / track A counter0
4	DI/O0	Output .0 enabled
5	DI/O1	State on input .1 direction / track B counter0
6	DI/O1	Output .1 enabled
7	DI/O2	State on input .3 track Z counter0
8	DI/O2	Output .2 enabled
9	DI/O3	State on input .3 / back-readable output 0.3
13	DI/O4	State on input .4 pulse / track A counter1
14	DI/O4	Output .4 enabled
15	DI/O5	State on input .5 direction / track B counter1
16	DI/O5	Output .5 enabled
17	DI/O6	State on input .6 track Z counter1
18	DI/O6	Output .6 enabled
19	DI/O7	State on input .7 / back readable output 0.7

Configuration “Frequency and Time measurement”

(hardware version 4.0, configuration version 1.0)

The function module contains 2 fast forward- and backward counters to measure frequency (rsp. revolution speed) or time period

Measure frequency / revolution speed

The counter inputs can be configured as single channel, detecting rising edges or as encoder interface, which quadruples (x4) the number of physical pulses.

Cycle duration / time measurement

The counter measures the time between two rising edges of the pulse input, encoders are treated as single channel. There is no direction detection

Compare

The compare output will become active when the counter value exceeds the configuration Compare value. To configure the compare value the new value is written into the setpoint register and activated by a bit inside of the control byte.

Output 0.3 rsp. 0.7 and the counter compare output are logical xor-ed. Setting the output value bit inverts the compare- output (and vice versa)

S7-Data

The 32 bit counters are latched with the read of the less significant byte (LSB) into an mirror register. The remaining bytes are read from there. So it is possible to use byte, word and dword access. Consider to always read the LSB first to get a new and consistent counter value. Due to S7's high endian addressing the physical LSB is read at offset 3 using byte and at offset 2 using word access.

The control byte works static, i.e. the control bits must be set and reset. Consider that the process image will be updated at control point time – wait 1 cycle between set and reset or use direct periphery access.

Function module DIO8-Z (8 digital in/ -outputs / encoder inputs)

Assignment of process image “Frequency and Time measurement”

The function module uses 12 byte in- and outputs in the process image.

Offset	I/O	Function	Description
0..3	I	Counter 0	32 bit forward and backward counter
	O	Setpoint register counter 0 (Config-, Compare-Register)	asynchronous setpoint counter0, operation control bit depended
4..7	I	Counter 1	32 bit forward and backward counter
	O	Setpoint register counter 2 (Config-, Compare-Register)	asynchronous setpoint of counter1 operation control bit depended
8	I	Input bits (status bits)	.0 pulse / trace A counter 0 .1 direction / trace B counter 0 .2 trace Z counter 0 .3 input 24V or status output 0.3 .4 pulse / trace A counter 1 .5 direction / trace B counter 1 .6 trace Z counter 1 .7 input 24V or status output 0.7
	O	Output enable bits	.0 - .7 output enable activate output driver of corresponding channel - not allowed when use channel as input - doesn't work at 0.-.2 and .4-.7 in 24V version
9	I	reserved	
	O	Output data bits	.0 - .7 output
10	I	Status byte	.0 NDR0 .1 NDR1 New Data Ready '1' the last read counter value was new '0' no new data (no pulse detected)
	O	Control byte	.0 reset NDR 0 While this bit is 1 the NDR0 bit in Status byte will be cleared .1 reset NDR 1 While this bit is 1 the NDR1 bit in Status byte will be cleared .2 set compare value 0 While this bit is 1 the output value from offset 0...3 will be carried over into the compare register of counter 0. .3 set compare value 1 While this bit is 1 the output value from offset 4...7 will be carried over into the compare register of counter 1. .4 res. .5 res. .6 Set Config 0 .7 Set Config 1 While this bit is 1 the output value from offset 0...3 / 4...7 will be carried over into the configuration register .0 SW-Gate 0=STOP, 1=RUN .1 Mode_INK 0=Puls/Dir, 1=encoder 4x .2 Mode_T 0= frequency measurement 1= time measurement .3 res. .4 - 5 limit of input bandwidth 00 = 500kHz 01 = 30kHz 10 = 8kHz 11 = 2kHz .6 - .15 res. .16 - .31 res.
11	I	Res.	
	O	Res.	

Function module DIO8-Z (8 digital in/ -outputs / encoder inputs)

Description of function pins “Frequency and Time measurement”

Pin	Identification	Function	Direction
1,11	+24V	common 24V-supply of outputs	Input / supply
2,12	5V(O)	common 5V-outputs to supply the encoders	Output
3	DI/O0+	positive switching input trace A / pulse counter0	Input
4	DI/O0-	negative switching input ¹⁾ trace /A counter0	Input
5	DI/O1+	positive switching input trace B / direction counter0	Input
6	DI/O1-	negative switching input ¹⁾ trace /B counter0	Input
7	DI/O2+	positive switching input trace Z counter0	Input
8	DI/O2-	negative switching input ¹⁾ trace /Z counter0	Input
9	DI/O3+	back-readable output ²⁾ 0.3	In / Out
10,2	0V	common reference potential	Input / supply
13	DI/O4+	positive switching input trace A counter1	Input
14	DI/O4-	negative switching input ¹⁾ trace /A counter1	Input
15	DI/O5+	positive switching input trace B counter1	Input
16	DI/O5-	negative switching input ¹⁾ trace \B counter1	Input
17	DI/O6+	positive switching input trace Z counter1	Input
18	DI/O6-	negative switching input ¹⁾ trace /Z counter1	Input
19	DI/O7+	back readable output ²⁾ 0.7	In / Out

¹⁾ keep pin unconnected at hardware version „24V“, optional use in version „5V“

²⁾ default configuration: input

Status-LEDs in configuration “Frequency and Time measurement”

Pin	Identification	Function
2,12	5V	5V-supply voltage ok
3	DI/O0	State on input .0 pulse / track A counter0
4	DI/O0	Output .0 enabled
5	DI/O1	State on input .1 direction / track B counter0
6	DI/O1	Output .1 enabled
7	DI/O2	State on input .3 track Z counter0
8	DI/O2	Output .2 enabled
9	DI/O3	State on input .3 / back-readable output 0.3
13	DI/O4	State on input .4 pulse / track A counter1
14	DI/O4	Output .4 enabled
15	DI/O5	State on input .5 direction / track B counter1
16	DI/O5	Output .5 enabled
17	DI/O6	State on input .6 track Z counter1
18	DI/O6	Output .6 enabled
19	DI/O7	State on input .7 / back readable output 0.7

Function module DIO8-Z (8 digital in/ -outputs / encoder inputs)

Configuration “Count-up counter or Time measurement”

(hardware version 4.0, configuration ver. 1.0)

The function module contains 6 fast forward-counters. The counter mode can be changed to measure time period.

To measure frequency the PLC's timebase must be used.

For compatibility purposes to other configurations the counters are grouped into 2 channels with 3 counter each.

Count up

The counter inputs are configured as single channel, detecting rising edges with 16 bit.

Cycle duration / time measurement

The counter measures the time between two rising edges of the pulse input in timesteps of $1\mu\text{s}$ or $250\mu\text{s}$.

Compare

In this configuration are no compare outputs.

Program

The 16 bit counters are latched with the read of the less significant byte (LSB) into an mirror register. The remaining byte is read from there. So it is possible to use byte, word and dword access. Consider to always read the LSB first to get a new and consistent counter value. Due to S7's high endian addressing the physical LSB of a DW is read at offset 3 using byte and at offset 2 using word access.

The payload data of this configuration are 16 bit words, the counter bytes are arranged this way to get 6 words (using “L IW”)

The bits of the control byte works static, i.e. the control bits must be set and reset. Consider that the process image will be updated at control point time – wait 1 cycle between set and reset or use direct periphery access.

Function module DIO8-Z (8 digital in/ -outputs / encoder inputs)

Assignment of process image “Count-up counter or Time measurement”

The function module uses 12 byte in- and outputs in the process image.

Offset	I/O	Function	Description
0..1	I	Channel 0, counter 0	16 bit forward counter or period time
2..3	I	Channel 0, counter 1	16 bit forward counter or period time
0..3	O	Config-register channel 0, counter 0 - 2	configuration data buffer, control bit depended
4..5	I	Channel 1, counter 0	16 bit forward counter or period time
6..7	I	Channel 1, counter 1	16 bit forward counter or period time
4..7	O	Config-register channel 0, counter 0 - 2	configuration data buffer, control bit depended
8	I	Input bits (status bits) or MSB Channel 0, counter 2	.0 state of input channel 0, counter 0 .1 state of input channel 0, counter 1 .2 state of input channel 0, counter 2 .3 input 24V or status output 0.3 .4 state of input channel 1, counter 0 .5 state of input channel 0, counter 1 .6 state of input channel 0, counter 2 .7 input 24V or status output 0.7
	O	Output enable bits	.3, .7 output enable activate output driver of corresponding channel (0.-.2 and .4-.7 ignored)
9	I	reserved or LSB Channel 0, counter 2	
	O	Output data bits	.3, .7 output data (0.-.2 and .4-.7 ignored)
10	I	Status byte or MSB Channel 1, counter 2	
	O	Control byte	.0 resets channel 0, counter 0 - 2 .1 resets channel 0, counter 0 - 2 Writing this bits '1' resets the corresponding counter synchron .2 - .5 res. .6 Set Config channel 0 .7 Set Config channel 1 Writing this bits '1' the value from offset 0...3 / 4...7 will be carried over into the configuration register .0 - .2 Mode counter 0 - 2 0=counter, 1=period time count .3 - .5 Timestep (period time count only) 0= 250µs, 1=1 µs .6 - .7 limit of input bandwidth 00 = 500kHz 01 = 30kHz 10 = 8kHz 11 = 2kHz .8 - .11 Interrupt enable input .0 bis .7
11	I	reserved or LSB Channel 1, counter 2	
	O	Mux	.7 Multiplexor input bytes 8 - 11 0= Status 1= counter 2 or 5

Function module DIO8-Z (8 digital in/ -outputs / encoder inputs)

Description of function pins “Count-up counter or Time measurement”

Pin	Identification	Function	Direction
1,11	+24V	common 24V-supply of outputs	Input / supply
2,12	5V(O)	common 5V-outputs to supply the encoders	Output
3	DI/O0+	positive switching input pulse channel 0, counter 0	Input
4	DI/O0-	negative switching input ¹⁾ pulse channel 0, counter 0	Input
5	DI/O1+	positive switching input pulse channel 0, counter 1	Input
6	DI/O1-	negative switching input ¹⁾ pulse channel 0, counter 1	Input
7	DI/O2+	positive switching input pulse channel 0, counter 2	Input
8	DI/O2-	negative switching input ¹⁾ pulse channel 0, counter 2	Input
9	DI/O3+	back-readable output ²⁾ 0.4	Output
10,2	0V	common reference potential	Input / supply
13	DI/O4+	positive switching input pulse channel 1, counter 0	Input
14	DI/O4-	negative switching input ¹⁾ pulse channel 1, counter 0	Input
15	DI/O5+	positive switching input pulse channel 1, counter 1	Input
16	DI/O5-	negative switching input ¹⁾ pulse channel 1, counter 1	Input
17	DI/O6+	positive switching input pulse channel 1, counter 2	Input
18	DI/O6-	negative switching input ¹⁾ pulse channel 1, counter 2	Input
19	DI/O7+	back readable output ²⁾ 0.7	Output

¹⁾ keep pin unconnected at hardware version „24V“, optional use in version „5V“

²⁾ default configuration: input

Status-LEDs in configuration “ Count-up counter or measurement”

Pin	Identification	Function
2,12	5V	5V-supply voltage ok
3	DI/O0	State on input .0 pulse channel 0, counter 0
4	DI/O0	-
5	DI/O1	State on input .1 pulse channel 0, counter 1
6	DI/O1	-
7	DI/O2	State on input .2 pulse channel 0, counter 2
8	DI/O2	
9	DI/O3	State on input .3 / back-readable output 0.3
13	DI/O4	State on input .4 pulse channel 1, counter 0
14	DI/O4	-
15	DI/O5	State on input .5 pulse channel 1, counter 1
16	DI/O5	-
17	DI/O6	State on input .6 pulse channel 1, counter 2
18	DI/O6	
19	DI/O7	State on input .7 / back readable output 0.7

Function module DIO8-Z (8 digital in/ -outputs / encoder inputs)

Configuration „Synchronous Serial Interface“

(hardware version 4.0, configuration version 1.0)

The function module contains 2 Synchronous Serial Interfaces (SSI).

Structure

Each interface contains a configurable clock output, a bit-counter and a data shift register. The shift register includes always 32 bit, the transmission runs „MSB-first“, the LSB will be read and shifted shortly before the (next) rising clock edge.

The data register used in S7 will be updated after the last clock.

Due to 5V-/ RS422- level of the clock output this configuration doesn't run in the 24V-version.

Number of bits, clock-frequency, break length

The number of clocks is configurable from 1 to 32. After the clock burst a configurable break from 8 .. 64 μ s occurs.

The clock frequency is configurable from 62,5 kHz to 2 MHz.

Special funktions: Gray-Code, Parity, Latch

Optionally a Gray-Code-Decoder can be switched into the data input path.

At every shift event of the register the parity is determined. The state of the parity is mapped into the status register and must be read separately.

The latch offers sampling synchronized to a digital 24V-signal. „Disabled“ causes free running continuously sampling, at „High“ or „Low“ only during High- resp. Low-level. At switching edges the initiated transfer will be completed. Mode „Edge“ causes sampling initiated by both edges (rising and falling).

Function module DIO8-Z (8 digital in/ -outputs / encoder inputs)

Assignment of process image „Synchronous Serial Interface“

The function module uses 12 byte in- and outputs in the process image.

Offset	I/O	Function	Description
0..3	I	Data interface 0	32 bit data register
	O	Configuration setpoint register 0	asynchronous input of configuration data, s. control bit
4..7	I	Data interface 1	32 Bit Datenregister
	O	Configuration setpoint register 1	asynchronous input of configuration data, s. control bit
8	I	Input bits (status)0 status of clock-output / interface 0 .1 input data / interface 0 .2 status input or output 0.2 .3 24V-input (Latch interface 0) or status output 0.3 .4 status of clock-output / interface 1 .5 input data / interface 1 .6 status input or output 0.6 .7 24V-input (Latch interface 1) or status output 0.7	.0 status of clock-output / interface 0 .1 input data / interface 0 .2 status input or output 0.2 .3 24V-input (Latch interface 0) or status output 0.3 .4 status of clock-output / interface 1 .5 input data / interface 1 .6 status input or output 0.6 .7 24V-input (Latch interface 1) or status output 0.7
	O	Output enable bits	.0 - .7 output enable activate output driver of corresponding channel - .0 and .4 always output (Clock) - .1 and .5 always input (Data)
9	I	reserved	
	O	Output data bits	.0, .1, .4, .5 not connected (SSI signals) .2, .3, .6, .7 outputs
10	I	Status byte	.0 Parity bit interface 0 .1 Parity bit interface 1
	O	Control byte	.05 unused .6 Set configuration interface 0 .7 Set configuration interface 1 Writing '1' to these bits causes loading the configuration from setpoint register: .04 number of bits [1..32] -1 .5, .6 reserved .7 0: Dual Code, 1: Gray Code .8, .9 break length 0: 64 µs 1: 32 µs, 2: 16 µs, 3: 8 µs .10, .11 Latch 0: disabled, 1: high, 2: low, 3: edge .1214 clock-frequency 0: disabled, 1: 62,5 kHz, 2: 125 kHz, 3: 250 kHz 4: 500 kHz, 5: 1 MHz, 6: 1,5 MHz, 7: 2 MHz
11	I	reserved	
	O	reserved	

Function module DIO8-Z (8 digital in/ -outputs / encoder inputs)

Description of function pins configuration „Synchronous Serial Interface“

Pin	Identification	Function	Direction
1,11	+24V	common 24V-supply of outputs	Input / supply
2,12	5V(O)	common 5V-outputs to supply the encoders	Output
3	DI/O0+	positive switching output ¹⁾ clock interface 0	Output
4	DI/O0-	negative switching output ¹⁾ clock interface 0	Output
5	DI/O1+	positive switching input ¹⁾ data interface 0	Input
6	DI/O1-	negative switching input ¹⁾ data interface 0	Input
7	DI/O2+	positive switching general input / output ²⁾ 0.2	Input
8	DI/O2-	negative switching general input / output ²⁾ 0.2	Input
9	DI/O3+	back-readable output 24V ²⁾ 0.3	In / Out
10,2	0V	common reference potential	Input / supply
13	DI/O4+	positive switching Ausgang ¹⁾ clock interface 1	Output
14	DI/O4-	negative switching Ausgang ¹⁾ clock interface 1	Output
15	DI/O5+	positive switching Eingang ¹⁾ data interface 1	Input
16	DI/O5-	negative switching Eingang ¹⁾ data interface 1	Input
17	DI/O6+	positive switching general input / output ²⁾ 0.6	Input
18	DI/O6-	negative switching general input / output ²⁾ 0.6	Input
19	DI/O7+	back-readable output 24V ²⁾ 0.7	In / Out

¹⁾ default configuration, fixed

²⁾ default: input

Status-LEDs in configuration „Synchronous Serial Interface“

Pin	Identification	Function
2,12	5V	5V-supply voltage ok
3	DI/O0	State of clock-output Interface 0
4	DI/O0	Run: active during SSI-clock burst interface 0
5	DI/O1	State at data input interface 0
6	DI/O1	Output .1 enabled (LED only, no external function due to data input)
7	DI/O2	State at input .2
8	DI/O2	Output .2 enabled
9	DI/O3	State back-readable output .3
13	DI/O4	State of clock-output Interface 1
14	DI/O4	Run: active during SSI-clock burst interface 1
15	DI/O5	State at data input interface 1
16	DI/O5	Output .5 enabled (LED only, no external function due to data input)
17	DI/O6	State at input .6
18	DI/O6	Output .6 enabled
19	DI/O7	State back-readable output .7

Function module DIO8-Z (8 digital in/ -outputs / encoder inputs)

Hints for downloading functions from ConfigStage into DIO8Z

- ConfigStage : Enabling the Download-option in counter configuration extensive data are stored into system data. After successful download into the PLC the configuration will be transferred into the DIO8Z module at the next startup and stored remanent. After this the download-option can be disabled.
- If the system data of the PLC contain the configuration data of DIO8Z ("Download" activated)
and
if the DIO8Z contains another configuration,
and in the next run up (changeover from STOP to RUN) the physical download of the configuration data from the PLC into the DIO8Z is carried out. This download takes about 4 seconds.



During this time the PLC may NOT be switched off

and

no new download from ConfigStage into the PLC may be started.

- After a successful download of the counter configuration the configuration will be kept remanently in the DIO8Z-module after the next run up. Than the download-option can be deactivated.
- Older DIO8Z-version doesn't support configuration by ConfigStage
- In case of configuration error the operation system does following diagnostic buffer entries:

Event:	16# BF05
OB:	16# 00
PK:	16# FF
DatID 1/2:	16# 00 00
Add.info	1: start address of module
	2: Slotindex (0..10)
	3: 1: „Programming error“ - corrupt VME-data or hardware-error
	2: „no Data“ - Download-Option not enabled or SDB missing or corrupt
	3: Configuration in ConfigStage for old hardware but new hardware detected
	3: Configuration in ConfigStage for new hardware but old hardware detected

The PLC enters always STOP-state.

Periphery module E-Mess UI (U/I for L1-3, N)

General wiring of E-Mess UI

- compact periphery module for measurement of current, voltage and calculation power and energy for L1, L2, L3
- Measurement of current in neutral wire
- **4 current transformer-pins** (in/out) (I_{L1} , I_{L2} , I_{L3} , I_N , max. 5A)
- **Current transformers must be potential separated and may not be grounded. *)**
- **Current transformers may not be wired in idle mode**
- including 8-pin connector with a bolt flange on each side cage clamp contact technology with 2,5mm²

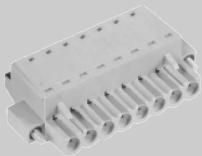

- **4x voltage contacts** (in- and out) for each of L1, L2, L3, N
- With compact and contact protected 4x2-pin connector with cage clamp 4mm² (2 pins per wire to combine wiring of multiple modules)



- 4x red / green diagnostic LEDs, one for each phase

red: error message for Px / N

green: all values in valid areas

off: no voltage applied

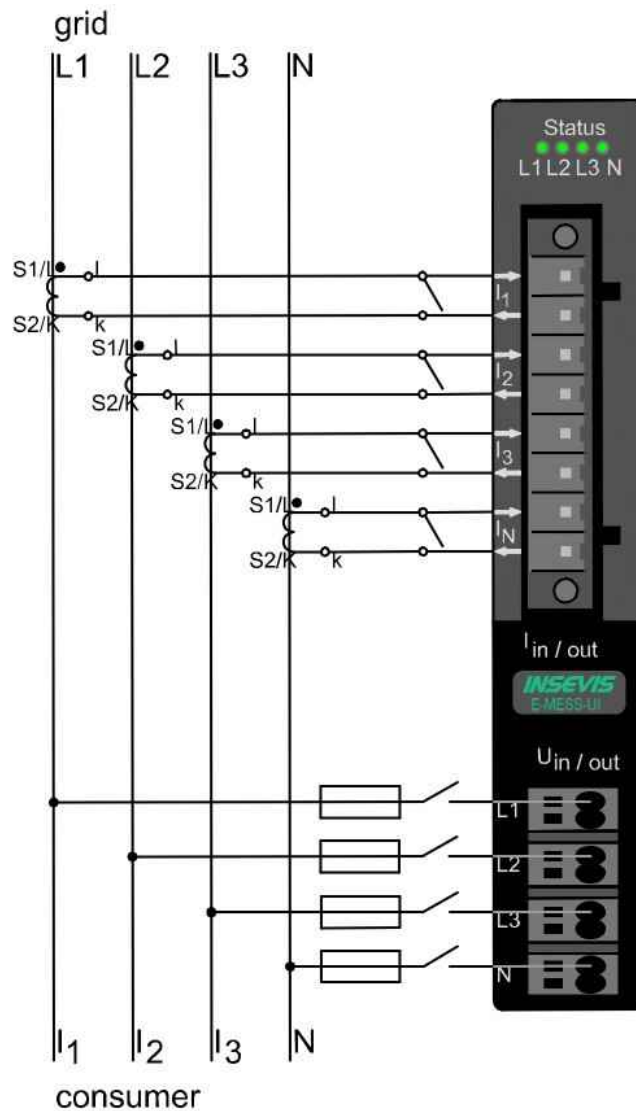

Figure above: Description and wiring of all connections of E-MESS-UI- module

***) At the connecting of measurement equipment via current transformer to the power circuit following instructions must be followed:**

- Secondary circuits of current transformers in low voltage systems may not be grounded, unless the measurement can be done by connecting to ground only.
- In secondary circuits of current transformers interrupting safety guards may not be used.
- Secondary conductors of transformers must be wired in that way, that no active parts can be touched by their isolation or cover, such as no contact with busbars.
- For connecting temporary measurements disconnecting terminals or shortcut clamps shall be provided.
- At the selection of current transformers the load by the secondary conductors (conductor cross section and length) must be considered.

Note:

- To reduce the influence of power resistors to the result of the measurement particularly transformer with a secondary rated current of .../1A shall be used.
- The voltage contact must be protected by short circuit protection equipment.
- The respective DIN VDE 0100-557:2014-10 contains the hint, that secondary circuits of current transformers may not be grounded in the low voltage facilities.

Periphery module E-Mess UI (U/I for L1-3, N)

Technical data PM E-Mess UI

Technical data E-Mess-UI	
Operating temperature range	-20°C ... +60°C (without condens.)
Storage temperature range	-30°C ... +80°C
Dimensions W x H x D (mm)	20 x 108 x 70 mm
Weight	ca. 150 g
Connection technology	connector with cage clamp for cross sections up to 2,5mm ² (current) connector with cage clamp for cross sections up to 4mm ² (voltage)
Load voltage L+	24V DC (10V ... 30V DC, connected by device supply)
Protection class	I
Degree of pollution	2
Power frequency	50 Hz, 60Hz switchable
Voltage measurement	
3-Phase 4-Wire systems with rating voltage (L -N)	Up to 230V eff.
Overvoltage category	300V CAT III
Rated impulse voltage	4kV
Measurement range L-N	Up to max. 350V eff.
Impedance	1 MΩ / Phase
Resolution	0,1 V
Measurement precision (typ.)	0,5%
Sampling frequency	8 kHz
Current measurement	
Rated current	1 / 5 A
Measurement range	0 - 6 A eff.
Impedance	14 mΩ
Resolution	0,1 A
Measurement precision (typ.)	0,5%
Sampling frequency	8 kHz

Periphery module E-Mess UI (U/I for L1-3, N)

E-Mess topology – E-Mess- module integration

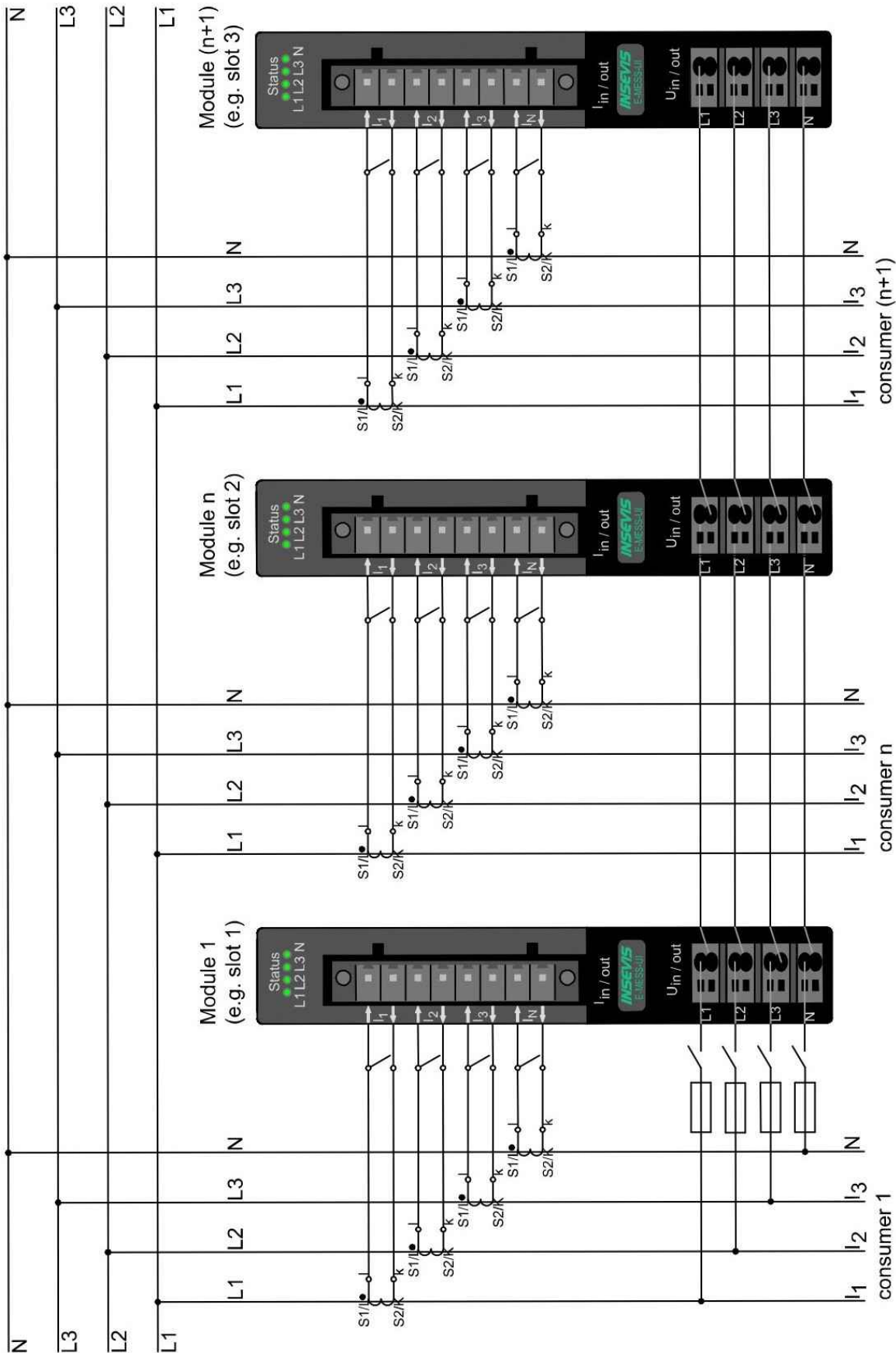

Periphery module E-Mess UI (U/I for L1-3, N)

E-Mess sample topology – system net

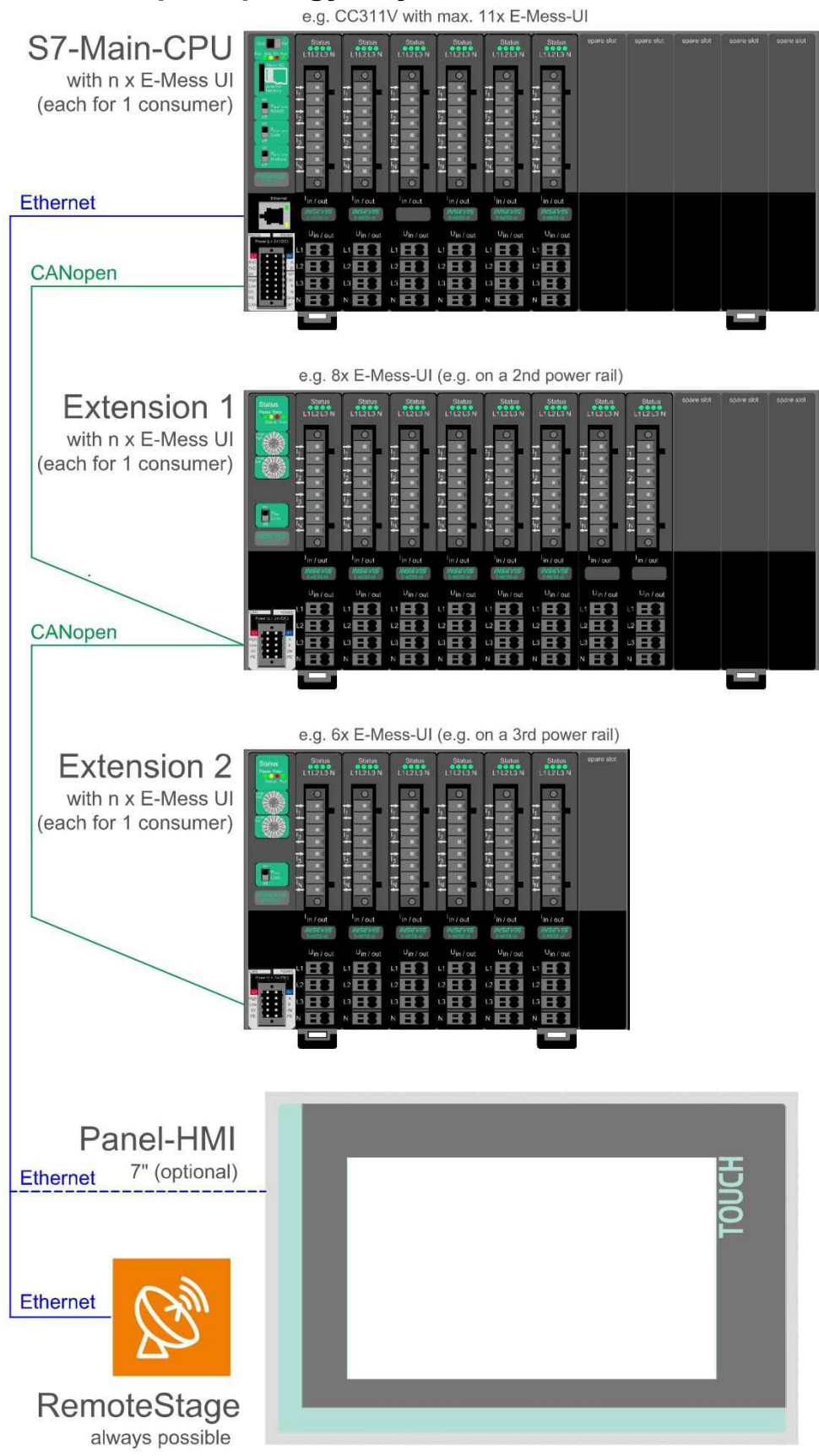

(max. length between CPU and extension 30m, no separated potential!)

Periphery module E-Mess UI (U/I for L1-3, N)

PM E-Mess-UI process data

The module occupies onboard 128 Byte in- and outputs in process image, only the lower 64 Byte of the input image will be synchronized with the process image at control point. The other process data are respective to the assignment accessible by direct periphery access.

As decentral periphery only the lower 64 Byte of the input process data will be transferred. Use SDO to access output data as well as input data on byte offset 64-128.

Process image inputs

(in process image as far length of process image is configured properly:)

Offset	Function	Format	Unit
0	Voltage L1	uint16	0,1V _{eff}
2	Voltage L2	uint16	0,1V _{eff}
4	Voltage L3	uint16	0,1V _{eff}
6	Net frequenca	uint16	0,01 Hz
8	Current L1	uint16	0,1 A _{eff}
10	Current L2	uint16	0,1 A _{eff}
12	Current L3	uint16	0,1 A _{eff}
14	Current N	uint16	0,1 A _{eff}
16	Effective power L1	int16	0,1 W
18	Effective power L2	int16	0,1 W
20	Effective power L3	int16	0,1 W
22	Apparent power L1	int16	0,1 VA
24	Apparent power L2	int16	0,1 VA
26	Apparent power L3	int16	0,1 VA
28	Power factor (cos φ) L1	int16	0,1% (10 ⁻³)
30	Power factor (cos φ) L2	int16	0,1% (10 ⁻³)
32	Power factor (cos φ) L3	int16	0,1% (10 ⁻³)
34	Phase angle L1	int16	0,1°
36	Phase angle L2	int16	0,1°
38	Phase angle L3	int16	0,1°
40	Active energy L1	int32	0,1 kWh
44	Active energy L2	int32	0,1 kWh
48	Active energy L3	int32	0,1 kWh
52	Apparent energy L1	uint32	0,1 kVAh
56	Apparent energy L2	uint32	0,1 kVAh
60	Apparent energy L3	uint32	0,1 kVAh

Periphery module E-Mess UI (U/I for L1-3, N)

Process image inputs

(only by direct periphery access:)

Offset	Function	Format	Unit
64...79	Reserved		
80	Tunnel state	uint16	
82	Tunnel ADE-register address	uint16	
84	Tunnel ADE-register data	uint16 / uint32	
88..95	Reserved		
96	Diagnostics / Condition bits (set by EMESS, cleared by reading L PEW) .0 Overcurrent L1 .1 L2 .2 L3 .3 Overvoltage L1 .4 L2 .5 L3 .6 Undervoltage L1 .7 L2 .8 L3 .9 Res. .10 Res. .11 Net frequency 0: 50Hz / 1:60 Hz .12 Res. .13 Phasing wrong .14 Res. .15 Data invalid:(compare with A96.15: if similar = setup ok if unsimilar = setup running	uint16	0,1 A _{eff}
98	Threshold overcurrent	uint16	0,1 A _{eff}
100	Threshold overvoltage	uint16	0,1 V _{eff}
102	Threshold undervoltage	int16	0,1 V _{eff}
104	Current transformer- transfer factor primary current	int16	
106	Current transformer- transfer factor secondary current	int16	
108	Current transformer- error correction transfer factor L1	int16	0,1% (10 ⁻³)
110	Current transformer- error correction transfer factor L2	int16	0,1% (10 ⁻³)
112	Current transformer- error correction transfer factor L3	int16	0,1% (10 ⁻³)
114	Current transformer- error correction transfer factor N	int16	0,1% (10 ⁻³)
116	Current transformer- error correction phase angle L1	int16	°min
118	Current transformer- error correction phase angle L2	int16	°min
120	Current transformer- error correction phase angle L3	int16	°min
122	Reserved (internal use)	uint16	
124	Reserved (internal use)	uint16	
126	Reserved (internal use)	uint16	

Periphery module E-Mess UI (U/I for L1-3, N)

Process image outputs

(only by direct periphery access:)

Offset	Function	Format	Unit
0-38	Reserved		
40	Active energy L1	int32	0,1 kWh
44	Active energy L2	int32	0,1 kWh
48	Active energy L3	int32	0,1 kWh
52	Apparent energy L1	uint32	0,1 kVAh
56	Apparent energy L2	uint32	0,1 kVAh
60	Apparent energy L3	uint32	0,1 kVAh
64...79	Reserved		
80	Tunnel Command	uint16	
82	Tunnel ADE-register address	uint16	
84	Tunnel ADE-register data	uint16 / uint32	
88..95	Reserved		
96	Control bits: .010 Res. .11 Net frequency 0:50 / 1:60 Hz .1214 Res. .15 Setup -requirement (Bit toggeling) after writing of setup data in offset 98..120	uint16	
98	Threshold overcurrent	uint16	0,1 A _{eff}
100	Threshold overvoltage	uint16	0,1 V _{eff}
102	Threshold undervoltage	int16	0,1 V _{eff}
104	Current transformer- transfer factor primary current	int16	
106	Current transformer- transfer factor secondary current	int16	
108	Current transformer- error correction transfer factor L1	int16	0,1% (10 ⁻³)
110	Current transformer- error correction transfer factor L2	int16	0,1% (10 ⁻³)
112	Current transformer- error correction transfer factor L3	int16	0,1% (10 ⁻³)
114	Current transformer- error correction transfer factor N	int16	0,1% (10 ⁻³)
116	Current transformer- error correction phase angle L1	int16	°min
118	Current transformer- error correction phase angle L2	int16	°min
120	Current transformer- error correction phase angle L3	int16	°min
122	Reserved (internal use)	uint16	
124	Reserved (internal use)	uint16	
126	Reserved (internal use)	uint16	

INSEVIS - Gesellschaft für industrielle
Systemelektronik und Visualisierung mbH

Am Weichselgarten 7
D - 91058 Erlangen

Fon: +49(0)9131-691-440
Fax: +49(0)9131-691-444
Web: www.insevis.de
E-Mail: info@insevis.de

Zertifiziert nach DIN EN ISO 9001:2008